

THE GARDEN COLLECTION

Foxglove

HOUSE





A view from North West London towards Central London

WELCOME TO BEAUFORT PARK

The story of Beaufort Park is forever evolving – from its historic origins as the site of the world’s first airfield to today’s vibrant neighbourhood.

Situated in North West London, Beaufort Park is well connected, just a few stops away from Hampstead and Camden.



Beaufort Square

THE GARDEN COLLECTION

Overlooking the verdant Beaufort Square and surrounded by green space, these homes have quality finishes and stylish interiors, perfect for today's Londoner.

Set in 25 acres, with a landscaped parkland at its heart, Beaufort Park is leading the regeneration within this area of North West London, delivered through the St George bold vision and world-class designs.

BEAUFORT
PARK
London NW9



THIS IS MODERN LONDON LIVING

Discover a neighbourhood designed with the modern resident in mind. These beautiful homes boast exclusive on-site facilities, speedy connections to the city centre and landscaped green spaces.

FOXGLOVE HOUSE

Foxglove House features a distinctive design, set within a green and open environment, with stunning views of the picturesque Beaufort Square to the west and the courtyard gardens to the east. With a choice between a Studio, Manhattan, 1, 2, 3 & 4 bedroom apartments and penthouses, each home is light-filled and fitted with contemporary details. Residents of Foxglove House can enjoy Beaufort Park's on-site spa, gym, indoor pool, sauna and jacuzzi, placing everything you need in one convenient neighbourhood.



SITE PLAN

- 1 Show Apartments & Marketing Suite
- 2 Landscaped Parkland
- 3 The Spa and Gym
- 4 Jun Ming Xuan Chinese Restaurant
- 5 Italian Restaurant
- 6 Dry Cleaners
- 7 Business / Community Rooms and Estate Management Suite
- 8 Café
- 9 Tesco Express
- 10 The Beaufort Pub
- 11 Bright Horizons
- 12 Hairven Hair & Beauty
- 13 Benham & Reeves Residential Lettings
- 14 Middlesex University
- 15 Hannah London Hair and MediSpa
- 16 Dentist
- 17 Japanese Convenience Store
- 18 Areaworks
- 19 Rouge Dance Studios
- 20 Playground

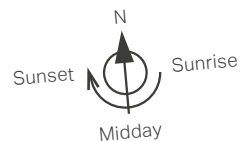

The site plan is indicative only and subject to change. In line with our policy of continuous improvement we reserve the right to alter the layout, building style, landscaping and specification at any time without notice. January 2020. All computer generated images are indicative only.



SPACE TO BREATHE

A home is more than a place to live. It should be a place to build connections. Beaufort Park has a thriving social scene. Meet friends in the coffee shop, go for food in the local restaurants or simply relax in the park. Find workspace in Areaworks, exercise in the on-site gym or unwind in The Spa.



Open spaces to enjoy

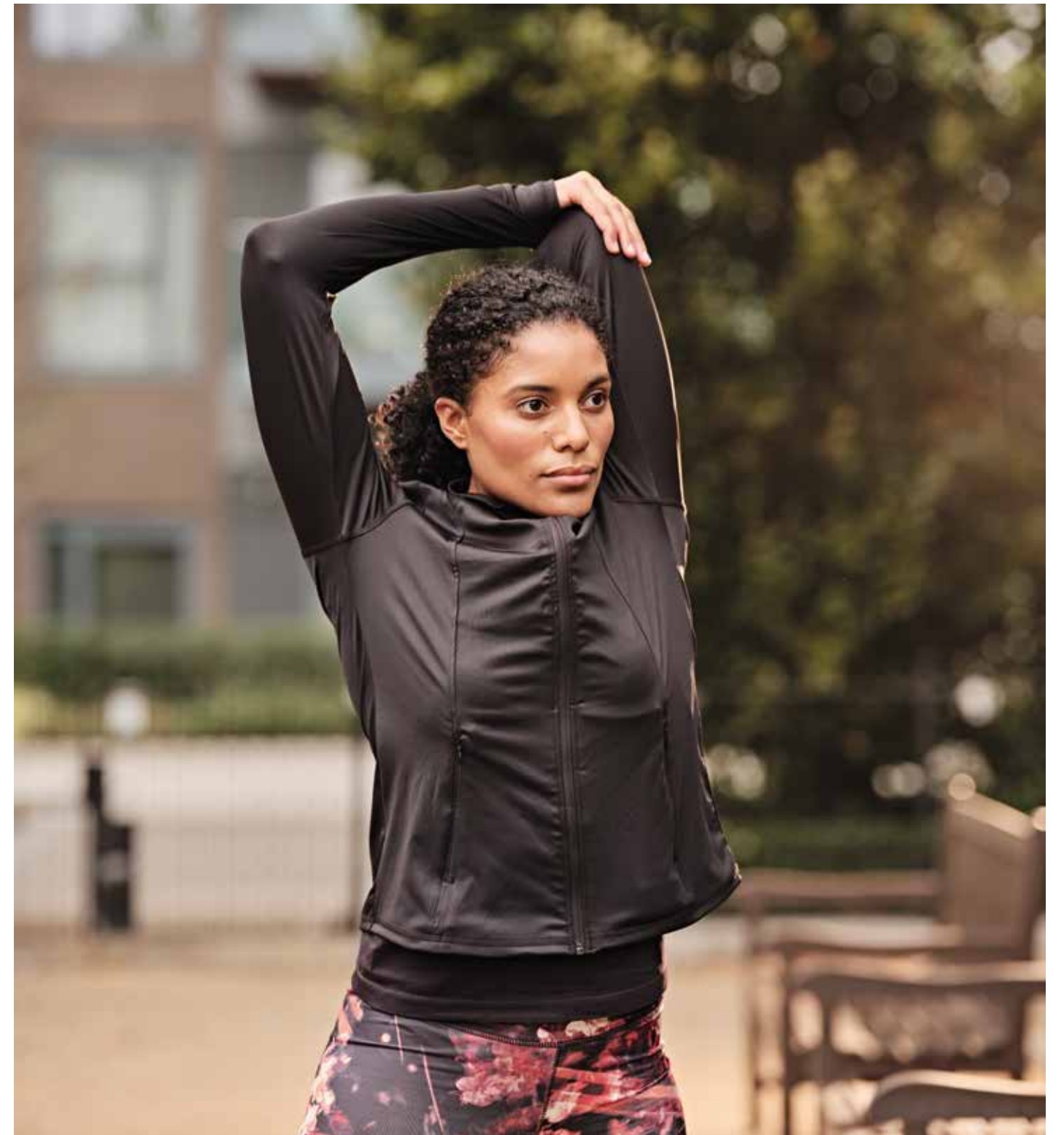

A run in the local park

Beaufort Park's beautifully landscaped grounds are a great space for unwinding.

Whether you want to take some exercise or relax in the sun, the continental-style courtyards, green space and manicured gardens offer a picturesque setting.

Each summer, the Concert in the Park invites residents to meet others within the community and watch musical performances of every genre, from jazz to steel bands, funk to opera.



A place to call home



After-work drinks with friends

TIME TO UNWIND

Everyone takes their coffee differently. Our coffee shop, can deliver your choice to any Beaufort Park address. Whether you want a cappuccino in bed or a mid-morning flat white on your balcony, put in your order and enjoy it alongside a host of pastries and other snacks.

The Beaufort Pub offers a great meeting space for catching up with friends and family over a Sunday roast or going for after-work drinks with colleagues.



Relax and reset



Beaufort Park Spa

SPA AND SWIMMING POOL

London life can be exciting but busy. That's why Beaufort Park has an impressive on-site spa, giving you the chance to indulge and take a little downtime. Complete with a pool, jacuzzi, treatment room, sauna and steam room, The Spa truly allows you to relax and pamper yourself.



The gym
16



Areaworks, co-working space

YOUR PERFECT WORKSPACE

Areaworks offers a local workspace where people and businesses can work and collaborate. Take advantage of the breakout spaces, private offices and coffee shop to create the working environment you need. Be inspired by regular workshops, expert talks and networking events.

The fully-equipped gym means there's no need to travel for a workout. With new, state-of-the-art cardiovascular machines including treadmills, three different types of exercise bikes and a cross trainer, it's the perfect place to work up a sweat.

UNIQUE NORTH WEST LONDON

North West London offers a unique combination – a welcoming and intimate village atmosphere with all the buzz of the city.

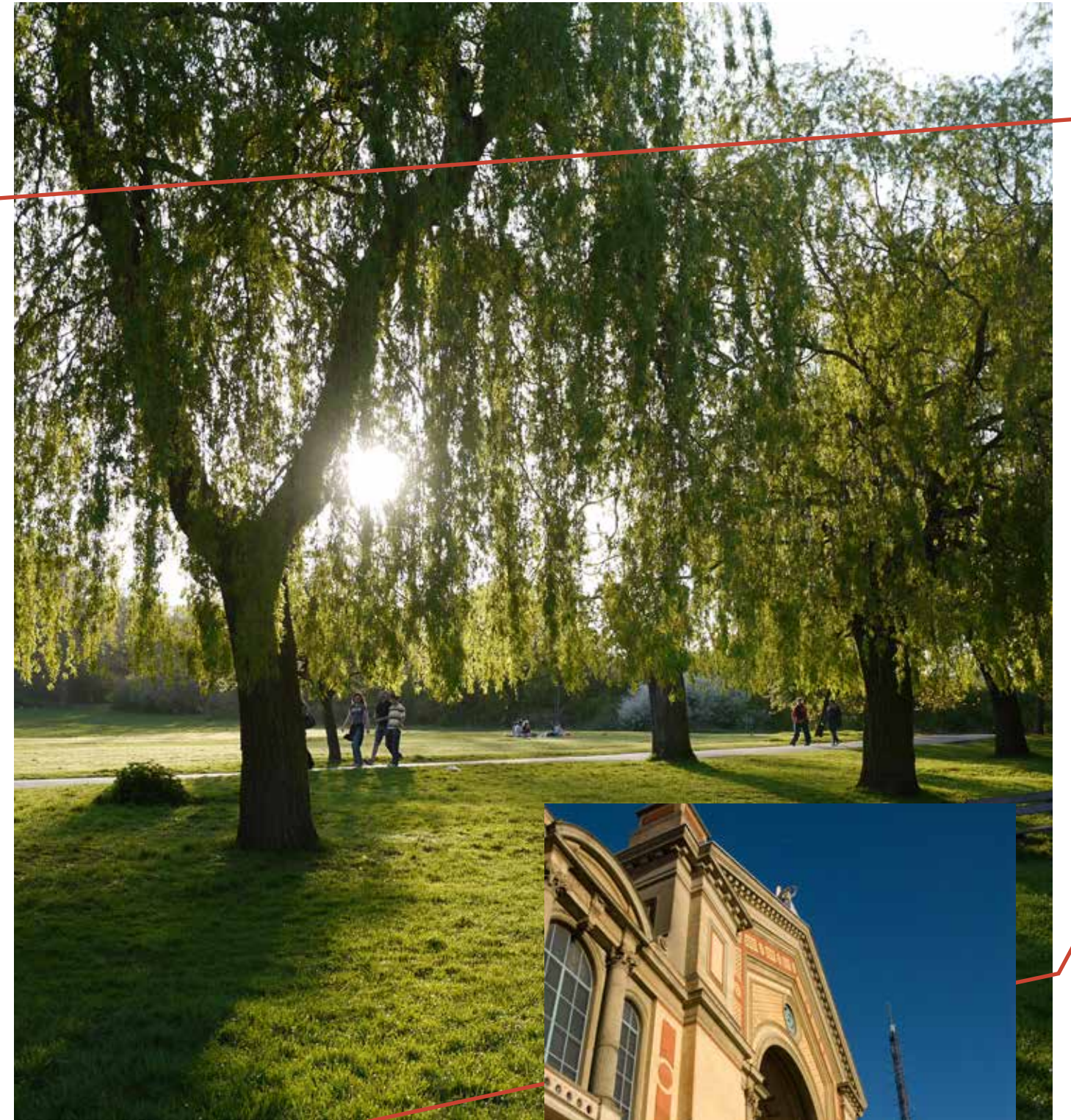

Hampstead Heath

This area's particular charm makes it well suited to every kind of resident – both locals and newcomers, those starting out and those settling down.

Spend a morning in fashionable Hampstead. Visit its varied boutique shops and chic coffee shops. Explore the wildlife, recreation and stunning views of Hampstead Heath. Discover the colourful narrowboats of Regent's Canal and the varied markets of Camden. And in the evening, head to a gig at Alexandra Palace.



Alexandra Palace

THE CAPITAL ON YOUR DOORSTEP

Beaufort Park is a short journey from the vibrant heart of London city centre. Stay close to the nightlife, shopping, business and entertainment at the capital's heart. At once modern and historic, local and international, London offers something for everyone.



Streets of North London

CULTURE

From intimate clubs to concert venues like the O2 Arena and the spectacular Royal Albert Hall, London hosts evening entertainment for every taste.

DINING

From the boutique restaurants of Soho and Fitzrovia to the trendy eateries of the east, London's gastronomic delights are easily reached from Beaufort Park.

SHOPPING

Whether you prefer big-name brands or high-street fashion, London is the place to shop. Jump on the Northern line to reach both hidden treasures and old favourites such as Harrods or take a short five-minute drive to Brent Cross for some retail therapy.

SPECTACLE

The capital is renowned for its exciting architecture and scenery, modern and classical. Among these are London's nine Royal Parks and the endlessly changing vista of the River Thames.



Bang Bang Oriental

TASTE OF THE EAST

Bang Bang Oriental Foodhall, London's newest and largest Asian food hall, is located a short distance from Beaufort Park.

Seating over 450 people, Bang Bang Oriental Foodhall is home to 33 individual pan-Asian food traders serving everything from sushi to laksa, Thai curries to steamed buns. This is the perfect spot to spend a weekend afternoon with friends and family.



Noodles in the food hall



Bang Bang Oriental



King's Cross St Pancras

KING'S CROSS

A short tube ride away from Beaufort Park, King's Cross is easily accessed via the Northern line. Its proximity places countless job opportunities moments away from Beaufort Park.



King's Cross Station

LONDON'S NEW TECH HUB

Google have set up new headquarters in King's Cross, welcoming 7,000 new professionals. Other nearby creative and media businesses include Facebook, Universal Music, YouTube and Nike.



STAY CONNECTED

London's transport network is fast and reliable, placing the city and beyond right on your doorstep.



Just a five-minute walk from Beaufort Park, the Northern line runs through Colindale tube station, transporting you to King's Cross St Pancras in 21 minutes and Leicester Square in 27 minutes. The 24-hour weekend tube makes commuting and going out much easier.

For travelling outside of London, Hendon Central connects to the National Rail network, while the Eurostar can be boarded from King's Cross St. Pancras. Additionally, bus connections and the A1, M1 and M25 are just moments away.

Colindale Station ⊖	Beaufort Park RAF Museum Middlesex University Bang Bang Oriental Foodhall
Hendon Central 3 mins ⊖	Mainline services to Central London and London Luton Airport
Brent Cross 5 mins ⊖	Brent Cross Shopping Centre
Hampstead 12 mins ⊖	Hampstead Village and Hampstead Heath
Camden Town 19 mins ⊖	Camden Market ZSL London Zoo The Roundhouse Theatre
King's Cross St. Pancras 21 mins ⊖ ⊕ ⊗ ⊙ ⊚ ⊛ ⊜	Google YouTube Facebook British Library University of the Arts London Eurostar Paris – 2 hours 25 minutes
Leicester Square 27 mins ⊖ ⊕	West End Theatre District Covent Garden Chinatown Bond Street

Timings are approximate. Source www.tfl.gov.uk



* Map representative and not to scale

OUTSTANDING EDUCATION

Beaufort Park is within easy reach of many of London's finest schools, with enough choice for everyone. And from UCL to Imperial College, London's universities are among the finest in the world.



Studying at Areaworks

PRIMARY SCHOOLS

- 1 Goldbeaters Primary School
- 2 St Joseph's Catholic Primary School
- 3 The Hyde School
- 4 Barnfield Primary School
- 5 Orion Primary School

SECONDARY SCHOOLS

- 1 Hasmonean High School
- 2 Hendon School
- 3 Canons High School

PRIVATE SCHOOLS

- 1 The Haberdashers' Aske's Boys' School (UK top 10*)
- 2 The Haberdashers' Aske's School for Girls (UK top 10*)
- 3 Mill Hill School
- 4 Harrow School

LONDON UNIVERSITIES

- 1 Middlesex University
- 2 UCL – University College London
- 3 Imperial College London
- 4 Central Saint Martins, University of the Arts London
- 5 CASS Business School, City, University of London



1, 2, 3 & 4 BEDROOM APARTMENTS
AND PENTHOUSES

The Studio, Manhattan, 1, 2, 3 & 4 bedroom apartments have been designed for modern living, with light-filled spaces and contemporary interiors.



THE AVIATOR SPECIFICATION

The Aviator Specification is more than a design statement. It's an aesthetic that draws on the area's aviation history, through oak detailing and natural tones, while celebrating Beaufort Park's classic quality.

Studio Floorplan

FROM 323 SQ FT TO 389 SQ FT

The design of the studio apartment has been crafted with careful consideration to deliver efficient use of space and a light, airy feeling. A wealth of natural light floods the studios from the balcony / terrace that comes available with all apartments.

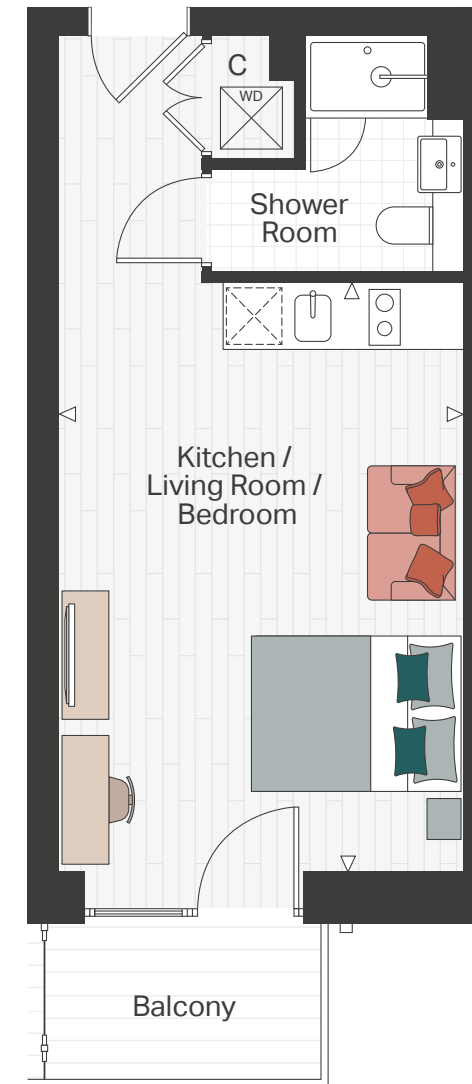

2648 - Studio	32.5 sq m	350 sq ft
Kitchen / Living Room / Bedroom	5.76m x 3.95m	18' 11" x 13' 0"
Balcony	4.1 sq m	44 sq ft

Manhattan

FROM 474 SQ FT TO 478 SQ FT

The one-bedroom Manhattan apartment has been designed as an open-plan layout to maximise the space available, creating flexible living. The style statement continues through the sliding doors and into the double bedroom which comes with fitted wardrobes.

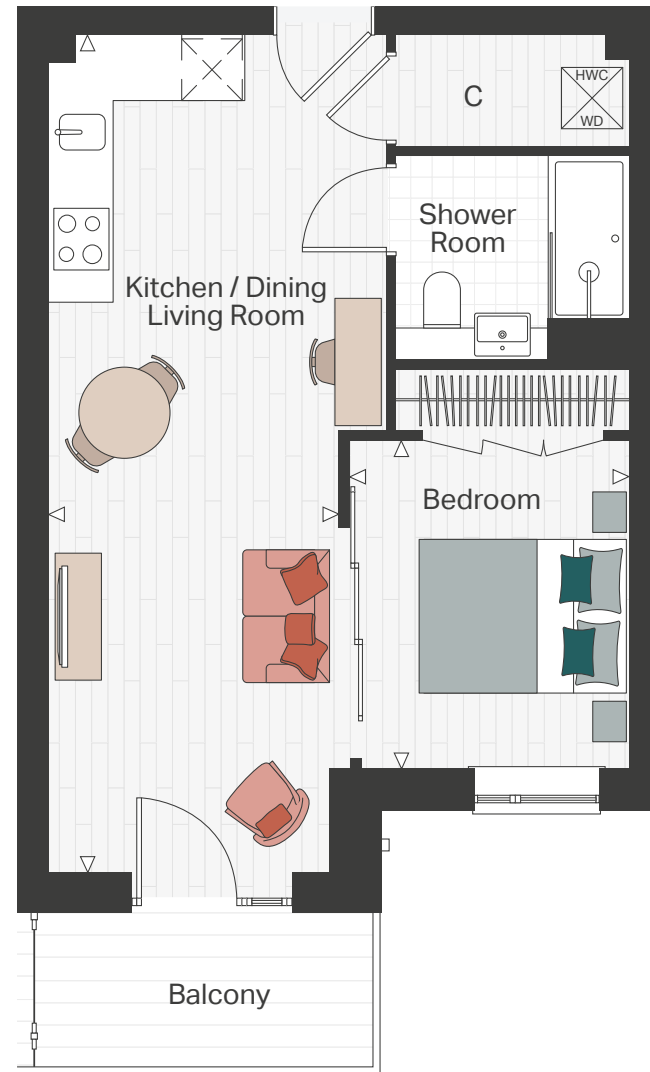

2650 – Manhattan	44.0 sq m	474 sq ft
Kitchen / Dining / Living Room	8.24m x 2.85m	27' 0" x 9' 4"
Bedroom	3.24m x 2.76m	10' 8" x 9' 1"
Balcony	4.9 sq m	53 sq ft

1 Bedroom

FROM 538 SQ FT TO 563 SQ FT

The spacious open-plan kitchen and living area are bathed in natural light from the windows and the elegant balcony leading off the living room. Stylish and meticulously finished, the shower room and separate well-proportioned bedroom with integrated wardrobes form the perfect place to relax.

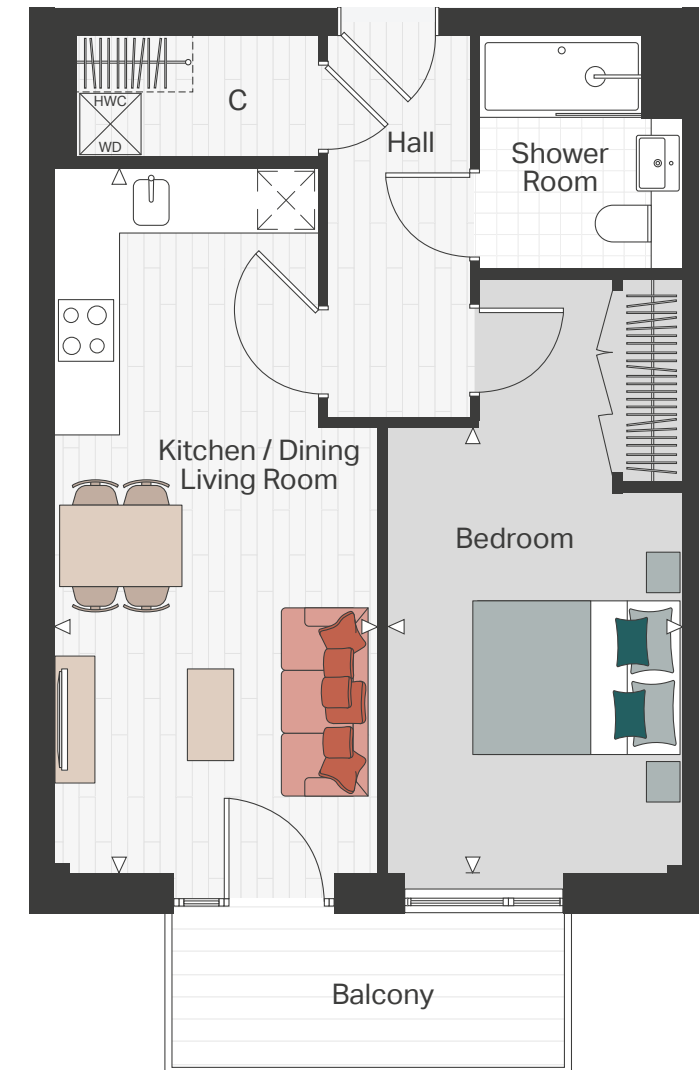

2684 – 1 Bedroom	51.1 sq m	550 sq ft
Living Space / Kitchen	6.94m x 3.20m	22' 9" x 10' 6"
Bedroom	4.38m x 2.91m	14' 4" x 9' 7"
Balcony	5.9 sq m	64 sq ft

2 Bedroom

FROM 753 SQ FT TO 853 SQ FT

Beautiful proportions and flexibility provide the perfect setting for entertainment and relaxation in this two-bedroom apartment. Both bathrooms feature high-quality fixtures and fittings and a modern colour palette.

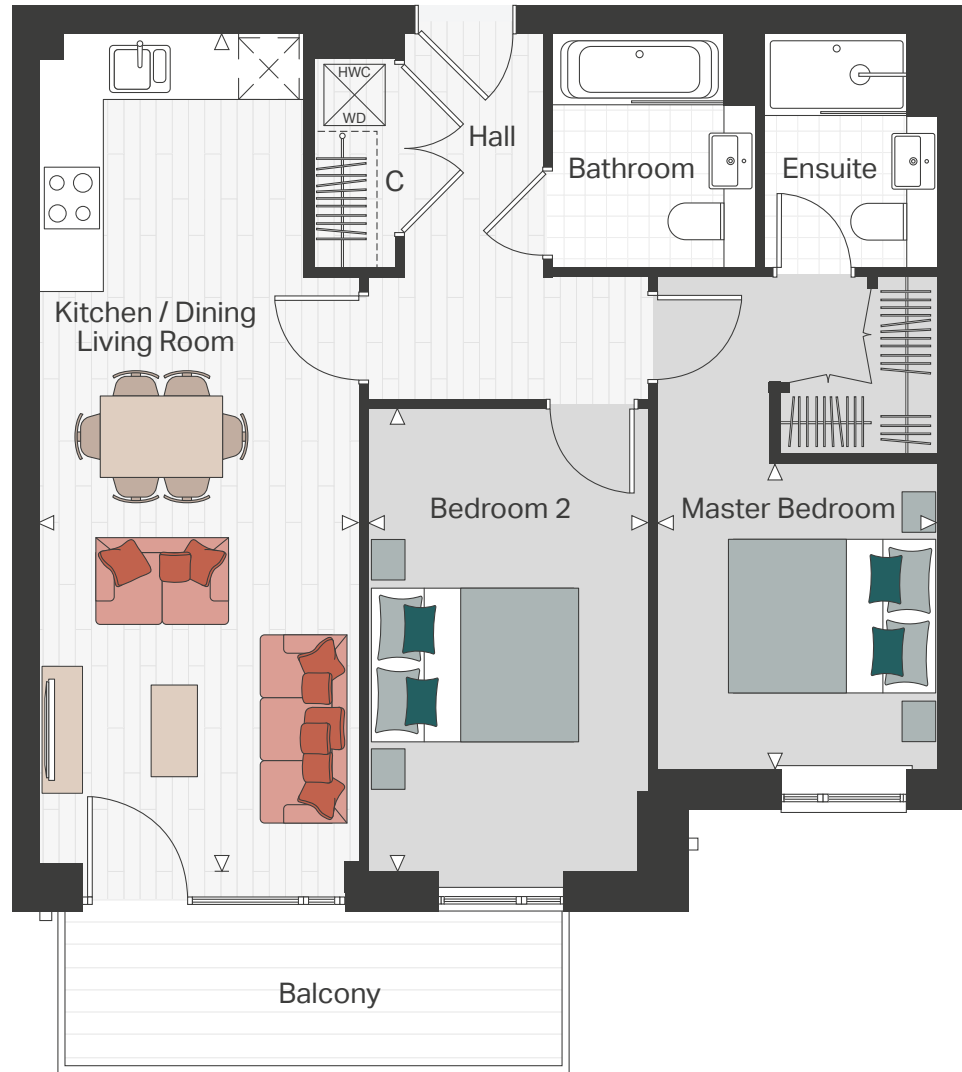

2667 – 2 Bedroom	70.0 sq m	753 sq ft
Kitchen / Dining / Living Room	8.16m x 3.16m	26' 9" x 10' 4"
Master Bedroom	3.00m x 2.76m	9' 10" x 9' 1"
Bedroom 2	4.55m x 2.75m	14' 11" x 9' 0"
Balcony	7.3 sq m	78 sq ft

3 Bedroom

FROM 1,036 SQ FT TO 1,361 SQ FT

This three-bedroom apartment is the epitome of modern open-plan living. The master bedroom benefits from a fitted dressing area adjacent to the ensuite bathroom. The elegant bathroom uses natural textures in a palette of warm greys to provide a contemporary and modern environment.

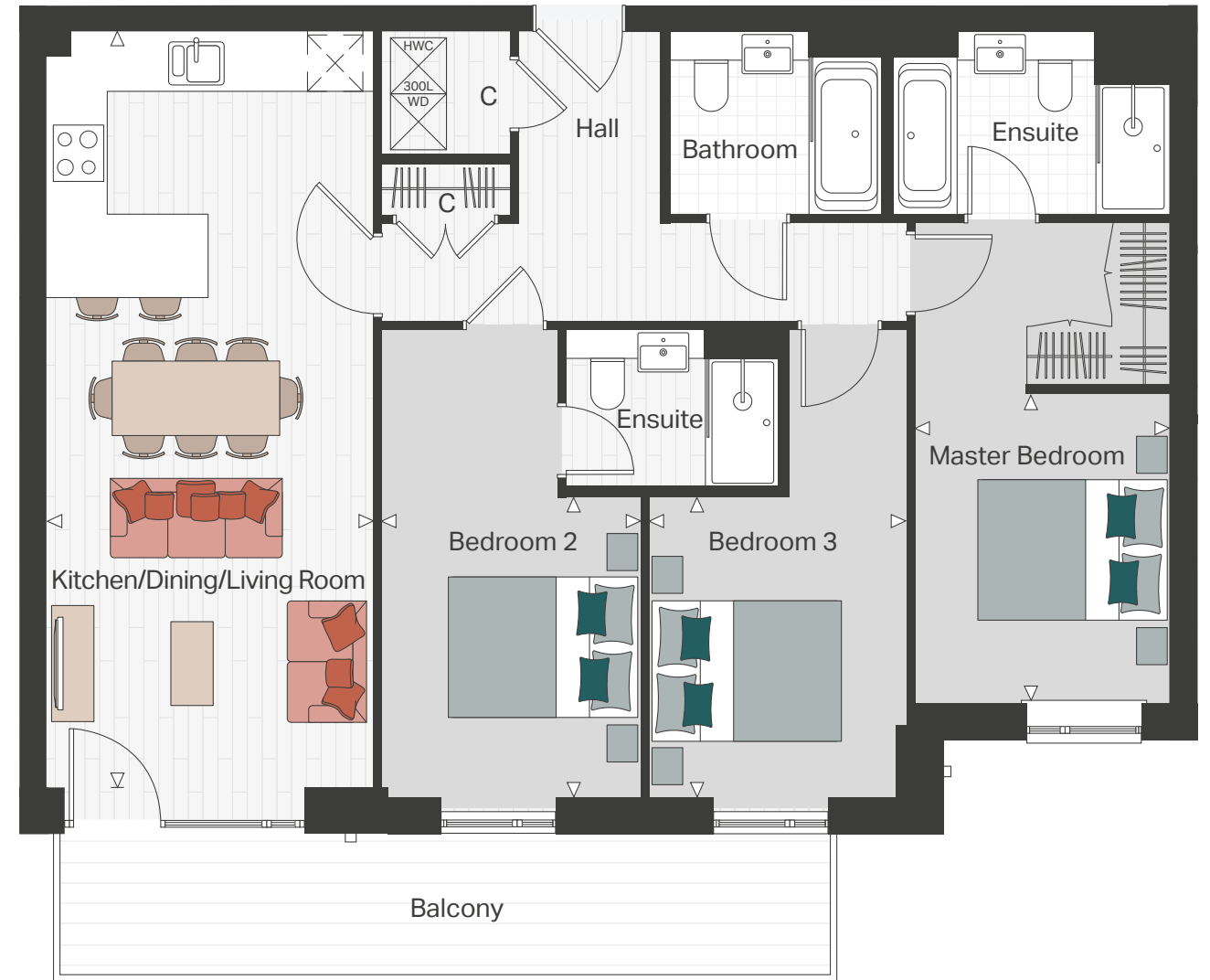

2717 – 3 Bedroom ELITE	96.4 sq m	1,038 sq ft
Kitchen / Dining / Living Room	8.14m x 3.52m	26' 8" x 11' 7"
Master Bedroom	3.33m x 2.75m	10' 11" x 9' 0"
Bedroom 2	3.23m x 2.79m	10' 7" x 9' 2"
Bedroom 3	3.23m x 2.76m	10' 7" x 9' 1"
Balcony	12.4 sq m	133 sq ft

GROUND FLOOR



FIRST FLOOR

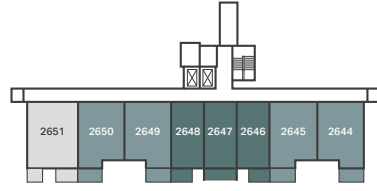

SECOND FLOOR



THIRD FLOOR



FOURTH FLOOR



FIFTH FLOOR



SIXTH FLOOR



SEVENTH FLOOR

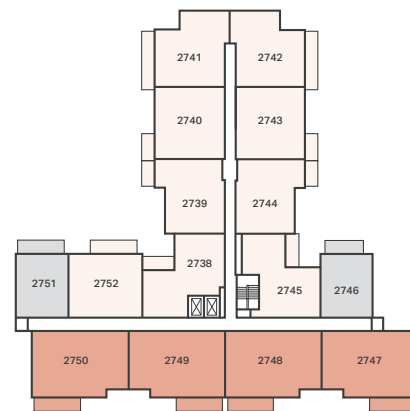

EIGHTH FLOOR

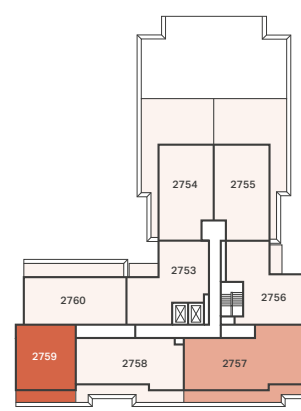

NINTH FLOOR

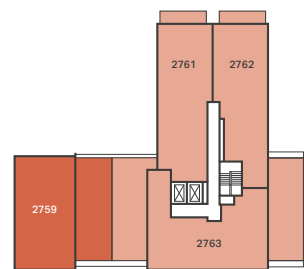

APARTMENT KEY

- Studio Apartment
- Manhattan 1 Bedroom Apartment
- 1 Bedroom Apartment
- 2 Bedroom Apartment
- 3 Bedroom Apartment
- 4 Bedroom Penthouse

ACCOMMODATION FINDER

Apt. No.	Floor	Bedrooms
2637	G	Studio
2638	G	Manhattan
2639	G	Manhattan
2640	G	1 Bedroom
2641	G	Manhattan
2642	G	Manhattan
2643	G	Studio

2644	1	Manhattan
2645	1	Manhattan
2646	1	Studio
2647	1	Studio
2648	1	Studio
2649	1	Manhattan
2650	1	Manhattan
2651	1	1 Bedroom

2652	2	2 Bedroom
2653	2	2 Bedroom
2654	2	1 Bedroom
2655	2	1 Bedroom
2656	2	1 Bedroom
2657	2	1 Bedroom
2658	2	1 Bedroom
2659	2	Studio

2660	2	2 Bedroom
2661	2	2 Bedroom
2662	2	1 Bedroom
2663	2	2 Bedroom
2664	2	2 Bedroom
2665	2	1 Bedroom
2666	2	2 Bedroom
2667	2	2 Bedroom
2668	2	1 Bedroom
2669	2	Studio
2670	2	1 Bedroom

2671	3	2 Bedroom
2672	3	2 Bedroom
2673	3	1 Bedroom
2674	3	1 Bedroom
2675	3	1 Bedroom
2676	3	1 Bedroom
2677	3	1 Bedroom
2678	3	1 Bedroom
2679	3	2 Bedroom

Apt. No.	Floor	Bedrooms	Type
2680	3	2 Bedroom	
2681	3	1 Bedroom	
2682	3	2 Bedroom	
2683	3	2 Bedroom	
2684	3	1 Bedroom	
2685	3	2 Bedroom	
2686	3	2 Bedroom	
2687	3	1 Bedroom	
2688	3	Manhattan	
2689	3	1 Bedroom	

2690	4	2 Bedroom	
2691	4	2 Bedroom	
2692	4	2 Bedroom	
2693	4	2 Bedroom	
2694	4	2 Bedroom	
2695	4	2 Bedroom	
2696	4	2 Bedroom	
2697	4	2 Bedroom	
2698	4	1 Bedroom	
2699	4	2 Bedroom	
2700	4	2 Bedroom	
2701	4	1 Bedroom	
2702	4	2 Bedroom	
2703	4	2 Bedroom	
2704	4	1 Bedroom	
2705	4	Manhattan	
2706	4	1 Bedroom	

2707	5	2 Bedroom	
2708	5	2 Bedroom	
2709	5	2 Bedroom	
2710	5	2 Bedroom	
2711	5	2 Bedroom	
2712	5	2 Bedroom	
2713	5	2 Bedroom	
2714	5	2 Bedroom	
2715	5	1 Bedroom	
2716	5	2 Bedroom	Elite
2717	5	3 Bedroom	Elite
2718	5	3 Bedroom	Elite
2719	5	2 Bedroom	Elite
2720	5	1 Bedroom	Elite
2721	5	1 Bedroom	
2722	5	2 Bedroom	

2723	6	2 Bedroom	Elite
2724	6	2 Bedroom	Elite
2725	6	2 Bedroom	Elite
2726	6	2 Bedroom	Elite
2727	6	2 Bedroom	Elite
2728	6	2 Bedroom	Elite
2729	6	2 Bedroom	Elite
2730	6	2 Bedroom	Elite
2731	6	1 Bedroom	Elite
2732	6	3 Bedroom	Elite
2733	6	3 Bedroom	Elite
2734	6	3 Bedroom	Elite
2735	6	3 Bedroom	Elite
2736	6	1 Bedroom	Elite
2737	6	2 Bedroom	Elite

2738	7	2 Bedroom	Elite
2739	7	2 Bedroom	Elite
2740	7	2 Bedroom	Elite
2741	7	2 Bedroom	Elite
2742	7	2 Bedroom	Elite
2743	7	2 Bedroom	Elite
2744	7	2 Bedroom	Elite
2745	7	2 Bedroom	Elite
2746	7	1 Bedroom	Elite
2747	7	3 Bedroom	Premier
2748	7	3 Bedroom	Premier
2749	7	3 Bedroom	Premier
2750	7	3 Bedroom	Premier
2751	7	1 Bedroom	Elite
2752	7	2 Bedroom	Elite

2753	8	2 Bedroom	Elite
2754	8	2 Bedroom	Elite
2755	8	2 Bedroom	Elite
2756	8	2 Bedroom	Elite
2757	8	3 Bedroom	Premier
2758	8	2 Bedroom	Elite
2759	8&9	4 Bedroom	Premier
2760	8	2 Bedroom	Elite

2761	9	3 Bedroom	Elite
2762	9	3 Bedroom	Elite
2763	9	3 Bedroom	Premier

Ground Floor

Ground Floor

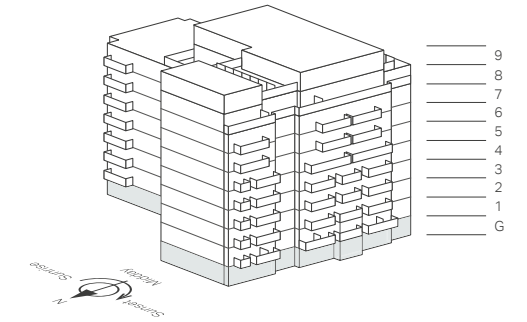

● 2637 – Studio	32.5 sq m	350 sq ft
Kitchen / Living room / Bedroom	5.76m x 3.95m	18' 11" x 13' 0"
Terrace	7.8 sq m	84 sq ft
● 2638 – Manhattan	44.4 sq m	478 sq ft
Living Space / Kitchen	8.24m x 2.90m	27' 0" x 9' 6"
Bedroom	3.24m x 2.76m	10' 8" x 9' 1"
Terrace	14.1 sq m	152 sq ft
● 2639 – Manhattan	44.0 sq m	474 sq ft
Living Space / Kitchen	8.24m x 2.85m	27' 0" x 9' 4"
Bedroom	3.24m x 2.76m	10' 8" x 9' 1"
Terrace	14.0 sq m	151 sq ft
● 2640 – 1 Bedroom	50.1 sq m	539 sq ft
Living Space / Kitchen	6.74m x 3.28m	22' 1" x 10' 9"
Bedroom	4.29m x 2.75m	14' 1" x 9' 0"
Terrace	12.3 sq m	132 sq ft
● 2641 – Manhattan	43.9 sq m	473 sq ft
Living Space / Kitchen	8.24m x 2.70m	27' 0" x 8' 10"
Bedroom	3.25m x 2.76m	10' 8" x 9' 1"
Terrace	13.9 sq m	150 sq ft
● 2642 – Manhattan	44.4 sq m	478 sq ft
Living Space / Kitchen	8.24m x 2.90m	27' 0" x 9' 6"
Bedroom	3.24m x 2.76m	10' 8" x 9' 1"
Terrace	14.2 sq m	153 sq ft
● 2643 – Studio	32.5 sq m	350 sq ft
Kitchen / Living room / Bedroom	5.76m x 3.95m	18' 11" x 13' 0"
Terrace	7.8 sq m	84 sq ft

APARTMENT KEY

- Studio Apartment
- Manhattan 1 Bedroom Apartment
- 1 Bedroom Apartment

FOXGLOVE HOUSE

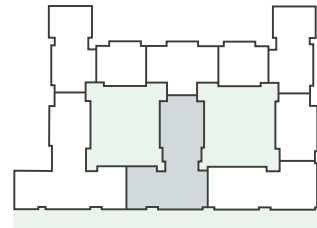

- 2 Ring Hob
- 4 Ring Hob
- Fridge / Freezer
- Hot Water Cylinder
- Hot Water Cylinder 300L
- Washer / Dryer
- Oven
- Below Counter Fridge
- C Cupboard

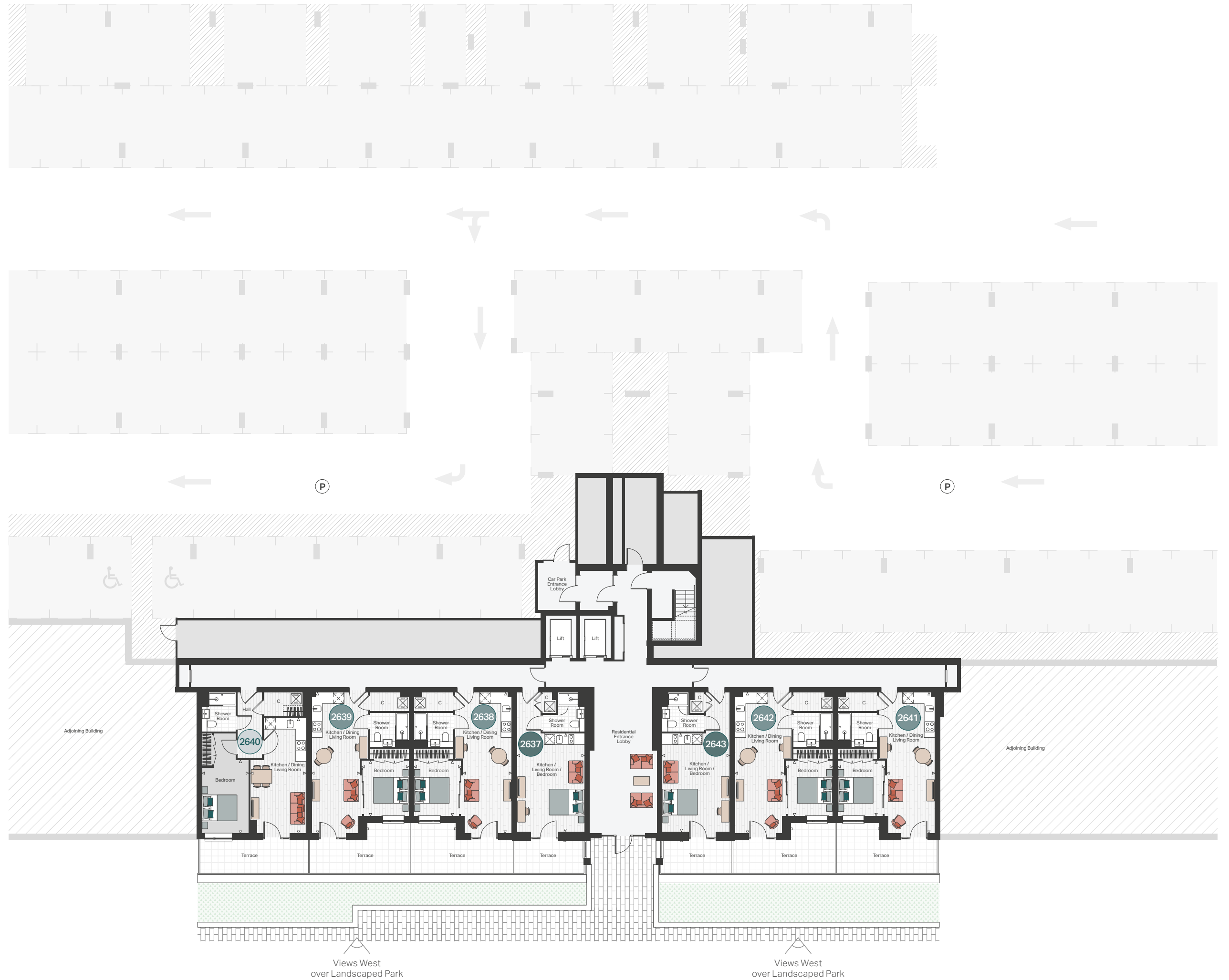

Floorplans shown for Foxglove Apartments are approximate measurements only. Exact layout and sizes may vary. All measurements may vary within a tolerance of 5%. Car park shown for illustrative purposes only. Car parking available subject to additional cost.

First Floor

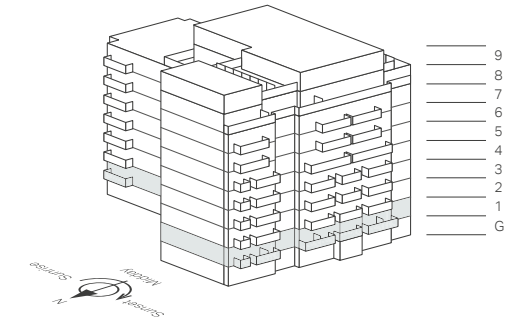

First Floor

● 2644 – Manhattan	43.9 sq m	473 sq ft
Living Space / Kitchen	8.24m x 2.70m	27' 0" x 8' 10"
Bedroom	3.25m x 2.76m	10' 8" x 9' 1"
Balcony	4.9 sq m	53 sq ft
● 2645 – Manhattan	44.4 sq m	478 sq ft
Living Space / Kitchen	8.24m x 2.90m	27' 0" x 9' 6"
Bedroom	3.24m x 2.76m	10' 8" x 9' 1"
Balcony	5.0 sq m	54 sq ft
● 2646 – Studio	32.5 sq m	350 sq ft
Kitchen / Living room / Bedroom	5.76m x 3.95m	18' 11" x 13' 0"
Balcony	4.1 sq m	44 sq ft
● 2647 – Studio	30.0 sq m	323 sq ft
Kitchen / Living room / Bedroom	5.15m x 3.98m	16' 11" x 13' 1"
Terrace	8.3 sq m	89 sq ft
● 2648 – Studio	32.5 sq m	350 sq ft
Kitchen / Living room / Bedroom	5.76m x 3.95m	18' 11" x 13' 0"
Balcony	4.1 sq m	44 sq ft
● 2649 – Manhattan	44.4 sq m	478 sq ft
Living Space / Kitchen	8.24m x 2.90m	27' 0" x 9' 6"
Bedroom	3.24m x 2.76m	10' 8" x 9' 1"
Balcony	5.0 sq m	54 sq ft
● 2650 – Manhattan	44.0 sq m	474 sq ft
Living Space / Kitchen	8.24m x 2.85m	27' 0" x 9' 4"
Bedroom	3.24m x 2.76m	10' 8" x 9' 1"
Balcony	4.9 sq m	53 sq ft
● 2651 – 1 Bedroom	50.1 sq m	539 sq ft
Living Space / Kitchen	6.74m x 3.28m	22' 1" x 10' 9"
Bedroom	4.29m x 2.75m	14' 1" x 9' 0"
Balcony	7.1 sq m	77 sq ft

APARTMENT KEY

- Studio Apartment
- Manhattan 1 Bedroom Apartment
- 1 Bedroom Apartment

FOXGLOVE HOUSE

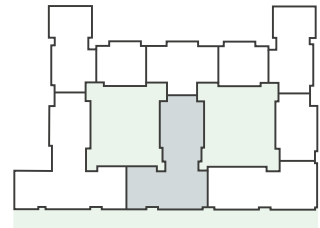

- 2 Ring Hob
- 4 Ring Hob
- Fridge / Freezer
- Hot Water Cylinder
- Hot Water Cylinder 300L
- Washer / Dryer
- Oven
- Below Counter Fridge
- C Cupboard

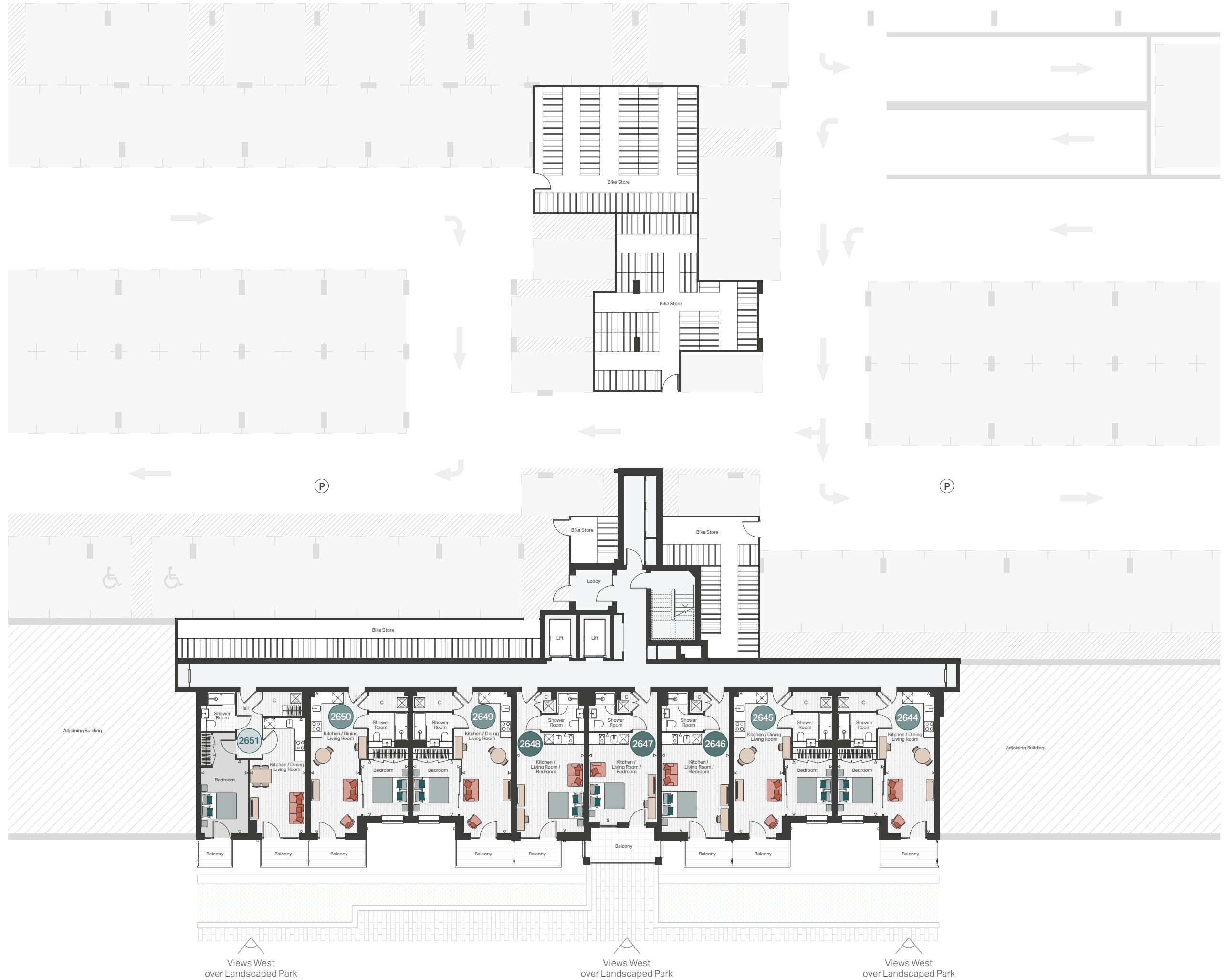

Floorplans shown for Foxglove Apartments are approximate measurements only. Exact layout and sizes may vary. All measurements may vary within a tolerance of 5%. Car park shown for illustrative purposes only. Car parking available subject to additional cost.

Second Floor

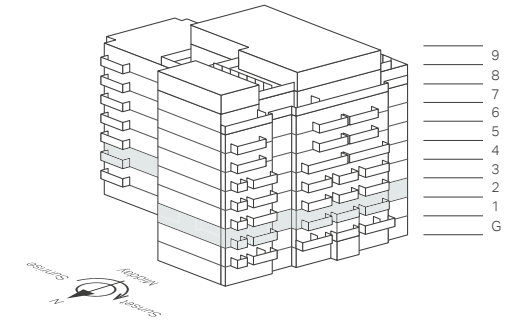

Second Floor

2652 – 2 Bedroom	74.2 sq m	799 sq ft
Living Space / Kitchen	5.72m x 4.12m	18' 8" x 13' 6"
Master Bedroom	3.66m x 2.75m	12' 0" x 9' 0"
Bedroom 2	3.65m x 2.77m	12' 0" x 9' 1"
Terrace	17.6 sq m	189 sq ft
2653 – 2 Bedroom	70.1 sq m	755 sq ft
Living Space / Kitchen	8.31m x 3.42m	27' 3" x 11' 3"
Master Bedroom	3.00m x 2.75m	9' 10" x 9' 0"
Bedroom 2	3.62m x 2.75m	11' 11" x 9' 0"
Terrace	28.6 sq m	308 sq ft
2654 – 1 Bedroom	50.0 sq m	538 sq ft
Living Space / Kitchen	7.41m x 3.03m	24' 4" x 9' 11"
Bedroom	4.62m x 2.75m	15' 2" x 9' 0"
Terrace	16.1 sq m	173 sq ft
2655 – 1 Bedroom	50.0 sq m	538 sq ft
Living Space / Kitchen	7.41m x 3.03m	24' 4" x 9' 11"
Bedroom	4.62m x 2.75m	15' 2" x 9' 0"
Terrace	13.7 sq m	147 sq ft
2656 – 1 Bedroom	50.1 sq m	539 sq ft
Living Space / Kitchen	6.81m x 4.03m	22' 4" x 13' 3"
Bedroom	3.16m x 2.75m	10' 4" x 9' 0"
Terrace	24.2 sq m	260 sq ft
2657 – 1 Bedroom	50.1 sq m	539 sq ft
Living Space / Kitchen	6.81m x 4.03m	22' 4" x 13' 3"
Bedroom	3.16m x 2.75m	10' 4" x 9' 0"
Terrace	24.2 sq m	260 sq ft
2658 – 1 Bedroom	50.0 sq m	538 sq ft
Living Space / Kitchen	7.41m x 3.03m	24' 4" x 9' 11"
Bedroom	4.62m x 2.75m	15' 2" x 9' 0"
Terrace	13.0 sq m	140 sq ft
2659 – Studio	36.1 sq m	389 sq ft
Kitchen / Living room / Bedroom	5.21m x 4.25m	17' 1" x 13' 11"
Terrace	10.9 sq m	117 sq ft
2660 – 2 Bedroom	70.1 sq m	755 sq ft
Living Space / Kitchen	8.31m x 3.42m	27' 3" x 11' 3"
Master Bedroom	3.00m x 2.75m	9' 10" x 9' 0"
Bedroom 2	3.62m x 2.75m	11' 11" x 9' 0"
Terrace	24.4 sq m	263 sq ft
2661 – 2 Bedroom	73.2 sq m	788 sq ft
Living Space / Kitchen	5.34m x 5.04m	17' 6" x 16' 6"
Master Bedroom	4.39m x 2.85m	14' 5" x 9' 4"
Bedroom 2	3.44m x 2.89m	11' 3" x 9' 6"
Terrace	16.6 sq m	179 sq ft

2662 – 1 Bedroom	50.0 sq m	538 sq ft
Living Space / Kitchen	5.67m x 3.35m	18' 7" x 11' 0"
Bedroom	3.57m x 2.90m	11' 9" x 9' 6"
Terrace	14.0 sq m	151 sq ft
2663 – 2 Bedroom	70.0 sq m	753 sq ft
Living Space / Kitchen	8.14m x 3.16m	26' 8" x 10' 4"
Master Bedroom	3.00m x 2.76m	9' 10" x 9' 1"
Bedroom 2	4.54m x 2.75m	14' 11" x 9' 0"
Balcony	7.3 sq m	78 sq ft
2664 – 2 Bedroom	70.0 sq m	753 sq ft
Living Space / Kitchen	8.14m x 3.16m	26' 8" x 10' 4"
Master Bedroom	3.00m x 2.76m	9' 10" x 9' 1"
Bedroom 2	4.54m x 2.75m	14' 11" x 9' 0"
Balcony	7.3 sq m	78 sq ft
2665 – 1 Bedroom	51.1 sq m	550 sq ft
Living Space / Kitchen	6.94m x 3.20m	22' 9" x 10' 6"
Bedroom	4.38m x 2.91m	14' 4" x 9' 7"
Terrace	3.9 sq m	42 sq ft
2666 – 2 Bedroom	70.0 sq m	753 sq ft
Living Space / Kitchen	8.16m x 3.16m	26' 9" x 10' 4"
Master Bedroom	3.00m x 2.75m	9' 10" x 9' 0"
Bedroom 2	4.55m x 2.75m	14' 11" x 9' 0"
Balcony	7.3 sq m	78 sq ft
2667 – 2 Bedroom	70.0 sq m	753 sq ft
Living Space / Kitchen	8.16m x 3.16m	26' 9" x 10' 4"
Master Bedroom	3.00m x 2.75m	9' 10" x 9' 0"
Bedroom 2	4.55m x 2.75m	14' 11" x 9' 0"
Balcony	7.3 sq m	78 sq ft
2668 – 1 Bedroom	51.1 sq m	550 sq ft
Living Space / Kitchen	6.79m x 3.16m	22' 3" x 10' 4"
Bedroom	5.15m x 2.95m	16' 11" x 9' 8"
Balcony	5.9 sq m	64 sq ft
2669 – Studio	31.4 sq m	338 sq ft
Kitchen / Living room / Bedroom	5.47m x 3.99m	17' 11" x 13' 1"
Terrace	8.3 sq m	89 sq ft
2670 – 1 Bedroom	52.3 sq m	563 sq ft
Living Space / Kitchen	7.87m x 3.58m	25' 10" x 11' 9"
Bedroom	4.22m x 3.00m	13' 10" x 9' 10"
Terrace	15.1 sq m	163 sq ft

APARTMENT KEY

- Studio Apartment
- 1 Bedroom Apartment
- 2 Bedroom Apartment

FOXGLOVE HOUSE

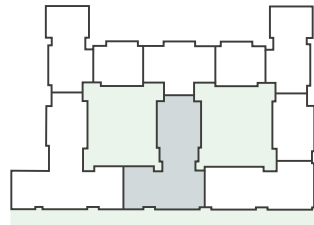

- 2 Ring Hob
- 4 Ring Hob
- Fridge / Freezer
- Hot Water Cylinder
- Hot Water Cylinder 300L
- Washer / Dryer
- Oven
- Below Counter Fridge
- C Cupboard



Floorplans shown for Foxglove Apartments are approximate measurements only. Exact layout and sizes may vary. All measurements may vary within a tolerance of 5%. Car park shown for illustrative purposes only. Car parking available subject to additional cost.

Third Floor

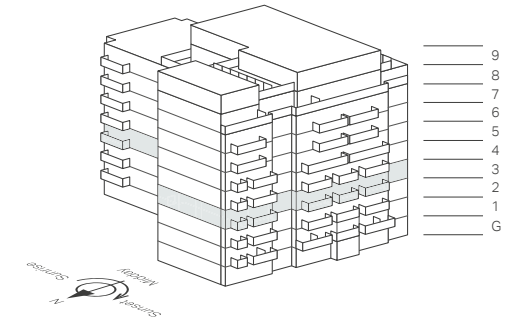

Third Floor

2671 – 2 Bedroom	74.2 sq m	799 sq ft
Living Space / Kitchen	5.72m x 4.12m	18' 8" x 13' 6"
Master Bedroom	3.66m x 2.75m	12' 0" x 9' 0"
Bedroom 2	3.65m x 2.77m	12' 0" x 9' 1"
Balcony	5.2 sq m	56 sq ft
2672 – 2 Bedroom	70.1 sq m	755 sq ft
Living Space / Kitchen	8.31m x 3.42m	27' 3" x 11' 3"
Master Bedroom	3.00m x 2.75m	9' 10" x 9' 0"
Bedroom 2	3.62m x 2.75m	11' 11" x 9' 0"
Balcony	4.6 sq m	50 sq ft
2673 – 1 Bedroom	50.0 sq m	538 sq ft
Living Space / Kitchen	7.41m x 3.03m	24' 4" x 9' 11"
Bedroom	4.52m x 2.75m	14' 10" x 9' 0"
Balcony	5.4 sq m	58 sq ft
2674 – 1 Bedroom	50.0 sq m	538 sq ft
Living Space / Kitchen	7.41m x 3.03m	24' 4" x 9' 11"
Bedroom	4.62m x 2.75m	15' 2" x 9' 0"
Balcony	5.9 sq m	64 sq ft
2675 – 1 Bedroom	50.1 sq m	539 sq ft
Living Space / Kitchen	6.81m x 4.03m	22' 4" x 13' 3"
Bedroom	3.16m x 2.75m	10' 4" x 9' 0"
Balcony	5.3 sq m	57 sq ft
2676 – 1 Bedroom	50.1 sq m	539 sq ft
Living Space / Kitchen	6.81m x 4.03m	22' 4" x 13' 3"
Bedroom	3.16m x 2.75m	10' 4" x 9' 0"
Balcony	5.3 sq m	57 sq ft
2677 – 1 Bedroom	50.0 sq m	538 sq ft
Living Space / Kitchen	7.41m x 3.03m	24' 4" x 9' 11"
Bedroom	4.62m x 2.75m	15' 2" x 9' 0"
Balcony	5.9 sq m	63 sq ft
2678 – 1 Bedroom	50.0 sq m	538 sq ft
Living Space / Kitchen	7.41m x 3.03 m	24' 4" x 9' 11"
Bedroom	4.52m x 2.75 m	14' 10" x 9' 0"
Balcony	5.0 sq m	54 sq ft
2679 – 2 Bedroom	70.1 sq m	755 sq ft
Living Space / Kitchen	8.31m x 3.42m	27' 3" x 11' 3"
Master Bedroom	3.00m x 2.75m	9' 10" x 9' 0"
Bedroom 2	3.62m x 2.75m	11' 11" x 9' 0"
Balcony	4.9 sq m	53 sq ft
2680 – 2 Bedroom	73.2 sq m	788 sq ft
Living Space / Kitchen	5.34m x 5.04m	17' 6" x 16' 6"
Master Bedroom	4.39m x 2.85m	14' 5" x 9' 4"
Bedroom 2	3.44m x 2.89m	11' 3" x 9' 6"
Balcony	5.9 sq m	63 sq ft

2681 – 1 Bedroom	50.0 sq m	538 sq ft
Living Space / Kitchen	5.67m x 3.35m	18' 7" x 11' 0"
Bedroom	3.57m x 2.90m	11' 9" x 9' 6"
Balcony	7.3 sq m	78 sq ft
2682 – 2 Bedroom	70.0 sq m	753 sq ft
Living Space / Kitchen	8.14m x 3.16m	26' 8" x 10' 4"
Master Bedroom	3.00m x 2.76m	9' 10" x 9' 1"
Bedroom 2	4.54m x 2.75m	14' 11" x 9' 0"
Balcony	7.3 sq m	78 sq ft
2683 – 2 Bedroom	70.0 sq m	753 sq ft
Living Space / Kitchen	8.14m x 3.16m	26' 8" x 10' 4"
Master Bedroom	3.00m x 2.76m	9' 10" x 9' 1"
Bedroom 2	4.54m x 2.75m	14' 11" x 9' 0"
Balcony	7.3 sq m	78 sq ft
2684 – 1 Bedroom	51.1 sq m	550 sq ft
Living Space / Kitchen	6.94m x 3.20m	22' 9" x 10' 6"
Bedroom	4.38m x 2.91m	14' 4" x 9' 7"
Balcony	5.9 sq m	64 sq ft
2685 – 2 Bedroom	70.0 sq m	753 sq ft
Living Space / Kitchen	8.16m x 3.16m	26' 9" x 10' 4"
Master Bedroom	3.00m x 2.75m	9' 10" x 9' 0"
Bedroom 2	4.55m x 2.75m	14' 11" x 9' 0"
Balcony	7.3 sq m	78 sq ft
2686 – 2 Bedroom	70.0 sq m	753 sq ft
Living Space / Kitchen	8.16m x 3.16m	26' 9" x 10' 4"
Master Bedroom	3.00m x 2.75m	9' 10" x 9' 0"
Bedroom 2	4.55m x 2.75m	14' 11" x 9' 0"
Balcony	7.3 sq m	78 sq ft
2687 – 1 Bedroom	51.1 sq m	550 sq ft
Living Space / Kitchen	6.79m x 3.16m	22' 3" x 10' 4"
Bedroom	5.15m x 2.95m	16' 11" x 9' 8"
Balcony	5.9 sq m	64 sq ft
2688 – Manhattan	44.2 sq m	476 sq ft
Living Space / Kitchen	7.87m x 2.76m	25' 10" x 9' 1"
Bedroom	3.88m x 2.75m	12' 9" x 9' 0"
Balcony	7.3 sq m	78 sq ft
2689 – 1 Bedroom	52.3 sq m	563 sq ft
Living Space / Kitchen	7.87m x 3.58m	25' 10" x 11' 9"
Bedroom	4.22m x 3.00m	13' 10" x 9' 10"
Balcony	8.8 sq m	94 sq ft

APARTMENT KEY

- Manhattan 1 Bedroom Apartment
- 1 Bedroom Apartment
- 2 Bedroom Apartment

FOXGLOVE HOUSE



- 2 Ring Hob
- 4 Ring Hob
- Fridge / Freezer
- Hot Water Cylinder
- Hot Water Cylinder 300L
- Washer / Dryer
- Oven
- Below Counter Fridge
- C Cupboard

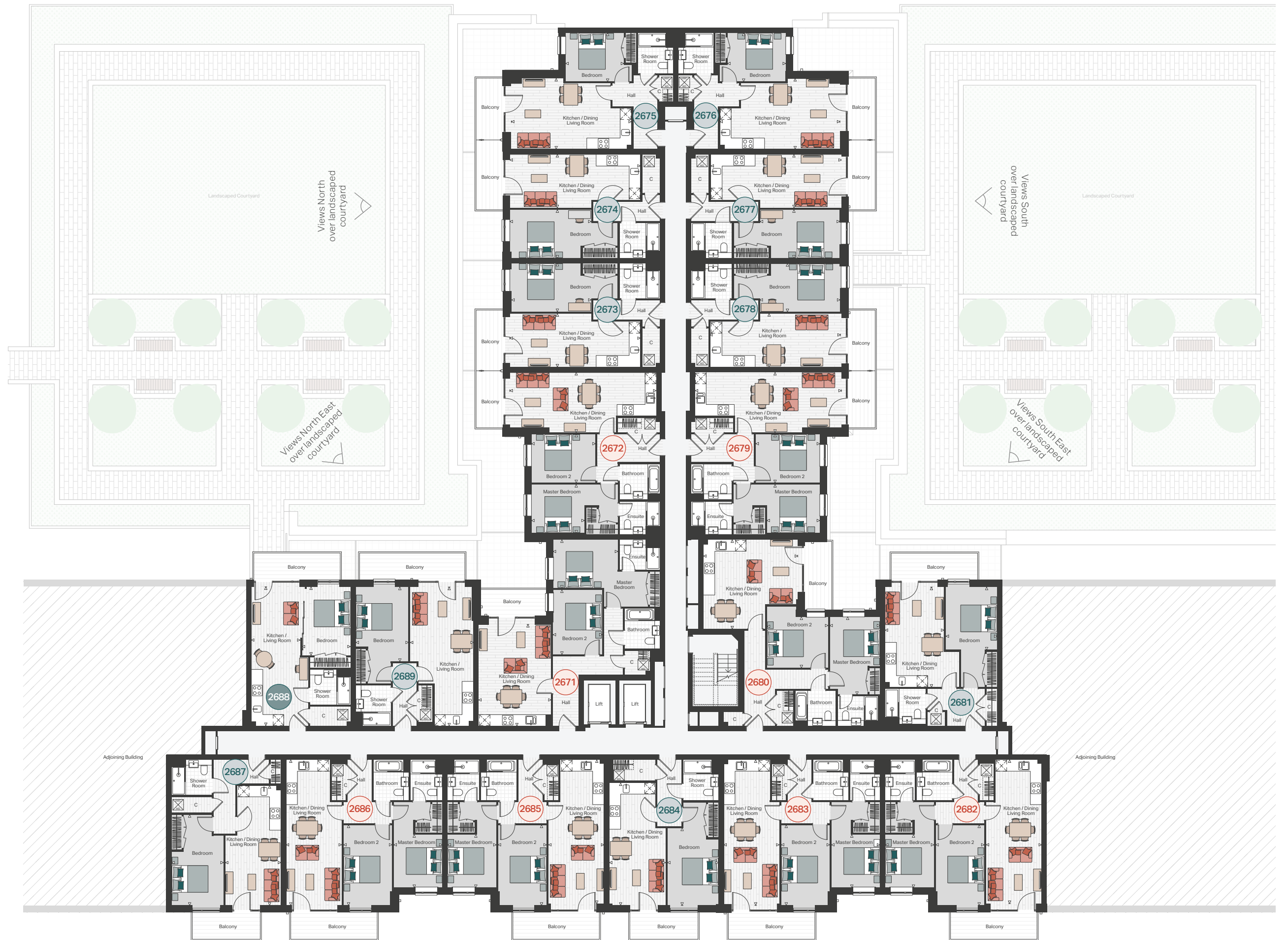

Floorplans shown for Foxglove Apartments are approximate measurements only. Exact layout and sizes may vary. All measurements may vary within a tolerance of 5%. Car park shown for illustrative purposes only. Car parking available subject to additional cost.

Views West over Landscaped Park

Views West over Landscaped Park

Views West over Landscaped Park

Fourth Floor

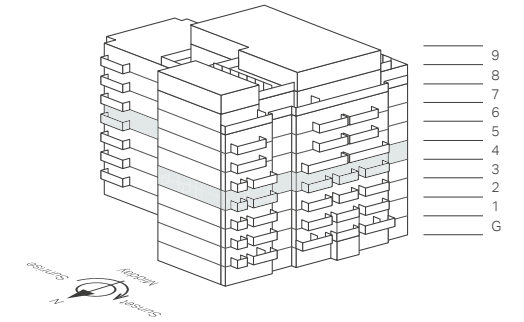

Fourth Floor

2690 – 2 Bedroom	74.2 sq m	799 sq ft
Living Space / Kitchen	5.72m x 4.12m	18' 8" x 13' 6"
Master Bedroom	3.66m x 2.75m	12' 0" x 9' 0"
Bedroom 2	3.65m x 2.77m	12' 0" x 9' 1"
Balcony	5.2 sq m	56 sq ft
2691 – 2 Bedroom	70.1 sq m	755 sq ft
Living Space / Kitchen	8.31m x 3.42m	27' 3" x 11' 3"
Master Bedroom	3.00m x 2.75m	9' 10" x 9' 0"
Bedroom 2	3.62m x 2.75m	11' 11" x 9' 0"
Balcony	4.6 sq m	50 sq ft
2692 – 2 Bedroom	77.3 sq m	832 sq ft
Living Space / Kitchen	8.50m x 3.43m	27' 10" x 11' 3"
Master Bedroom	3.92m x 2.75m	12' 10" x 9' 0"
Bedroom 2	4.82m x 2.75m	15' 10" x 9' 0"
Balcony	5.4 sq m	58 sq ft
2693 – 2 Bedroom	73.4 sq m	790 sq ft
Living Space / Kitchen	6.96m x 3.73m	22' 10" x 12' 3"
Master Bedroom	3.55m x 3.70m	11' 7" x 12' 2"
Bedroom 2	2.96m x 2.82m	9' 9" x 9' 3"
Balcony	11.2 sq m	120 sq ft
2694 – 2 Bedroom	73.4 sq m	790 sq ft
Living Space / Kitchen	6.96m x 3.73m	22' 10" x 12' 3"
Master Bedroom	3.55m x 3.70m	11' 7" x 12' 2"
Bedroom 2	2.96m x 2.82m	9' 9" x 9' 3"
Balcony	11.2 sq m	120 sq ft
2695 – 2 Bedroom	77.3 sq m	832 sq ft
Living Space / Kitchen	8.50m x 3.43m	27' 11" x 11' 3"
Master Bedroom	3.92m x 2.75m	12' 10" x 9' 0"
Bedroom 2	4.82m x 2.75m	15' 10" x 9' 0"
Balcony	5.0 sq m	54 sq ft
2696 – 2 Bedroom	70.1 sq m	755 sq ft
Living Space / Kitchen	8.31m x 3.42m	27' 3" x 11' 3"
Master Bedroom	3.00m x 2.75m	9' 10" x 9' 0"
Bedroom 2	3.62m x 2.75m	11' 11" x 9' 0"
Balcony	4.9 sq m	53 sq ft
2697 – 2 Bedroom	73.2 sq m	788 sq ft
Living Space / Kitchen	5.34m x 5.04m	17' 6" x 16' 6"
Master Bedroom	4.39m x 2.85m	14' 5" x 9' 4"
Bedroom 2	3.44m x 2.89m	11' 3" x 9' 6"
Balcony	5.9 sq m	63 sq ft
2698 – 1 Bedroom	50.0 sq m	538 sq ft
Living Space / Kitchen	5.67m x 3.35m	18' 7" x 11' 0"
Bedroom	3.57m x 2.90m	11' 9" x 9' 6"
Balcony	7.3 sq m	78 sq ft





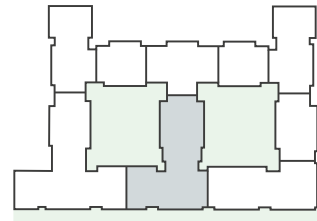

2699 – 2 Bedroom	70.0 sq m	753 sq ft
Living Space / Kitchen	8.14m x 3.16m	26' 8" x 10' 4"
Master Bedroom	3.00m x 2.76m	9' 10" x 9' 1"
Bedroom 2	4.54m x 2.75m	14' 11" x 9' 0"
Balcony	7.3 sq m	78 sq ft
2700 – 2 Bedroom	70.0 sq m	753 sq ft
Living Space / Kitchen	8.14m x 3.16m	26' 8" x 10' 4"
Master Bedroom	3.00m x 2.76m	9' 10" x 9' 1"
Bedroom 2	4.54m x 2.75m	14' 11" x 9' 0"
Balcony	7.3 sq m	78 sq ft
2701 – 1 Bedroom	51.1 sq m	550 sq ft
Living Space / Kitchen	6.94m x 3.20m	22' 9" x 10' 6"
Bedroom	4.38m x 2.91m	14' 4" x 9' 7"
Balcony	5.9 sq m	64 sq ft
2702 – 2 Bedroom	70.0 sq m	753 sq ft
Living Space / Kitchen	8.16m x 3.16m	26' 9" x 10' 4"
Master Bedroom	3.00m x 2.75m	9' 10" x 9' 0"
Bedroom 2	4.55m x 2.75m	14' 11" x 9' 0"
Balcony	7.3 sq m	78 sq ft
2703 – 2 Bedroom	70.0 sq m	753 sq ft
Living Space / Kitchen	8.16m x 3.16m	26' 9" x 10' 4"
Master Bedroom	3.00m x 2.75m	9' 10" x 9' 0"
Bedroom 2	4.55m x 2.75m	14' 11" x 9' 0"
Balcony	7.3 sq m	78 sq ft
2704 – 1 Bedroom	51.1 sq m	550 sq ft
Living Space / Kitchen	6.79m x 3.16m	22' 3" x 10' 4"
Bedroom	5.15m x 2.95m	16' 11" x 9' 8"
Balcony	5.9 sq m	64 sq ft
2705 – Manhattan	44.2 sq m	476 sq ft
Living Space / Kitchen	7.87m x 2.76m	25' 10" x 9' 1"
Bedroom	3.88m x 2.75m	12' 9" x 9' 0"
Balcony	7.3 sq m	78 sq ft
2706 – 1 Bedroom	52.3 sq m	563 sq ft
Living Space / Kitchen	7.87m x 3.58m	25' 10" x 11' 9"
Bedroom	4.22m x 3.00m	13' 10" x 9' 10"
Balcony	8.8 sq m	94 sq ft

APARTMENT KEY

- Manhattan 1 Bedroom Apartment
- 1 Bedroom Apartment
- 2 Bedroom Apartment

FOXGLOVE HOUSE



-  2 Ring Hob
-  4 Ring Hob
-  Fridge / Freezer
-  Hot Water Cylinder
-  Hot Water Cylinder 300L
-  Washer / Dryer
-  Oven
-  Below Counter Fridge
- C** Cupboard

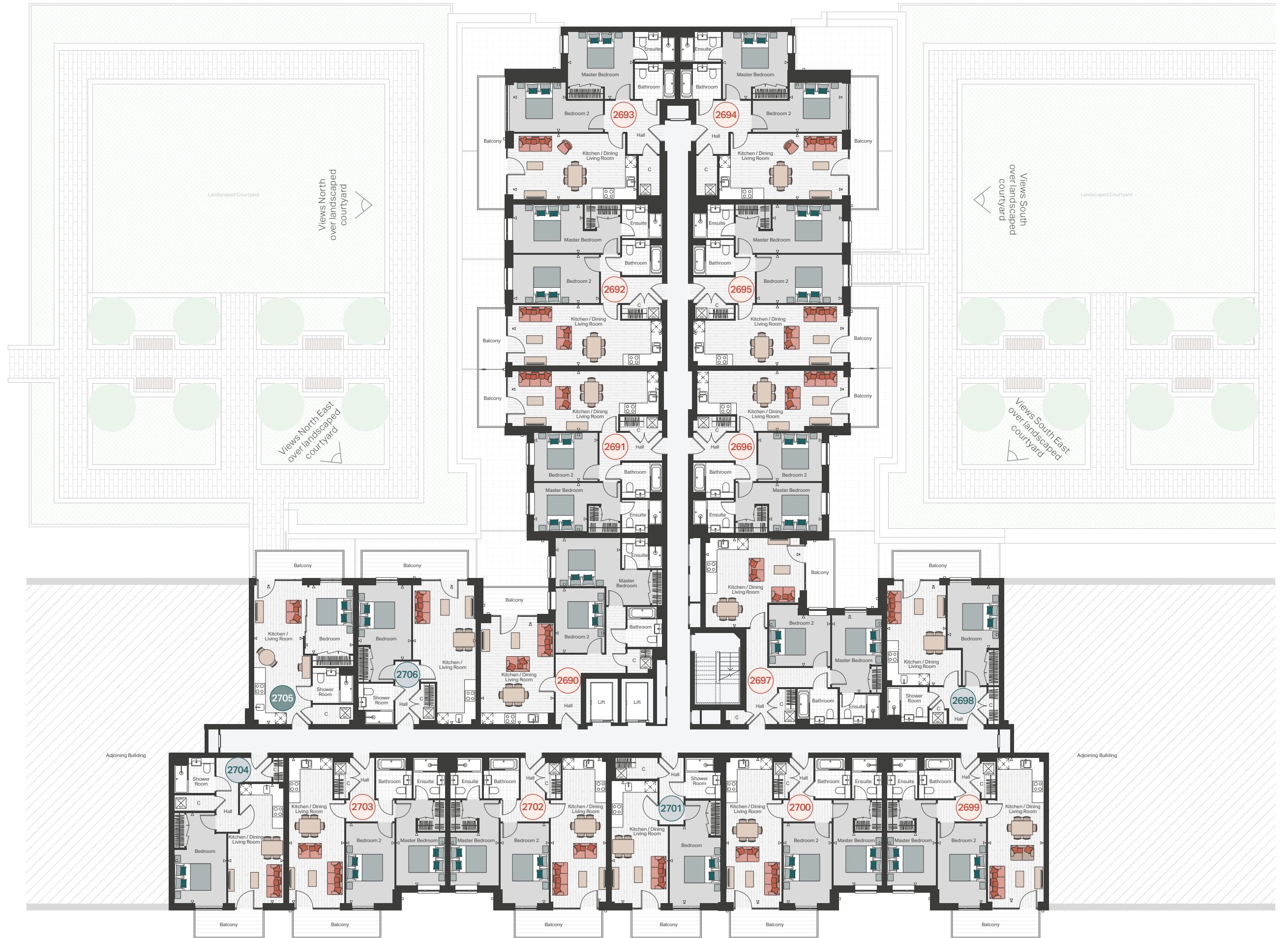

Floorplans shown for Foxglove Apartments are approximate measurements only. Exact layout and sizes may vary. All measurements may vary within a tolerance of 5%. Car park shown for illustrative purposes only. Car parking available subject to additional cost.

Fifth Floor

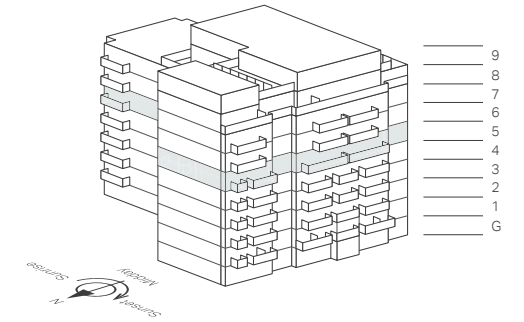

Fifth Floor

2707 – 2 Bedroom	74.2 sq m	799 sq ft
Living Space / Kitchen	5.72m x 4.12m	18' 8" x 13' 6"
Master Bedroom	3.66m x 2.75m	12' 0" x 9' 0"
Bedroom 2	3.65m x 2.77m	12' 0" x 9' 1"
Balcony	5.2 sq m	56 sq ft
2708 – 2 Bedroom	70.1 sq m	755 sq ft
Living Space / Kitchen	8.31m x 3.42m	27' 3" x 11' 3"
Master Bedroom	3.00m x 2.75m	9' 10" x 9' 0"
Bedroom 2	3.62m x 2.75m	11' 11" x 9' 0"
Balcony	4.6 sq m	50 sq ft
2709 – 2 Bedroom	77.3 sq m	832 sq ft
Living Space / Kitchen	8.50m x 3.43m	27' 11" x 11' 3"
Master Bedroom	3.92m x 2.75m	12' 10" x 9' 0"
Bedroom 2	4.82m x 2.75m	15' 10" x 9' 0"
Balcony	5.4 sq m	58 sq ft
2710 – 2 Bedroom	73.4 sq m	790 sq ft
Living Space / Kitchen	6.96m x 3.73m	22' 10" x 12' 3"
Master Bedroom	3.55m x 3.70m	11' 7" x 12' 2"
Bedroom 2	2.96m x 2.82m	9' 9" x 9' 3"
Balcony	11.2 sq m	120 sq ft
2711 – 2 Bedroom	73.4 sq m	790 sq ft
Living Space / Kitchen	6.96m x 3.73m	22' 10" x 12' 3"
Master Bedroom	3.55m x 3.70m	11' 7" x 12' 2"
Bedroom 2	2.96m x 2.82m	9' 9" x 9' 3"
Balcony	11.2 sq m	120 sq ft
2712 – 2 Bedroom	77.3 sq m	832 sq ft
Living Space / Kitchen	8.50m x 3.43m	27' 11" x 11' 3"
Master Bedroom	3.92m x 2.75m	12' 10" x 9' 0"
Bedroom 2	4.82m x 2.75m	15' 10" x 9' 0"
Balcony	5.0 sq m	54 sq ft
2713 – 2 Bedroom	70.1 sq m	755 sq ft
Living Space / Kitchen	8.31m x 3.42m	27' 3" x 11' 3"
Master Bedroom	3.00m x 2.75m	9' 10" x 9' 0"
Bedroom 2	3.62m x 2.75m	11' 11" x 9' 0"
Balcony	4.9 sq m	53 sq ft
2714 – 2 Bedroom	73.2 sq m	788 sq ft
Living Space / Kitchen	5.34m x 5.04m	17' 6" x 16' 6"
Master Bedroom	4.39m x 2.85m	14' 5" x 9' 4"
Bedroom 2	3.44m x 2.89m	11' 3" x 9' 6"
Balcony	5.9 sq m	63 sq ft
2715 – 1 Bedroom	50.0 sq m	538 sq ft
Living Space / Kitchen	5.67m x 3.35m	18' 7" x 11' 0"
Bedroom	3.57m x 2.90m	11' 9" x 9' 6"
Balcony	7.3 sq m	78 sq ft







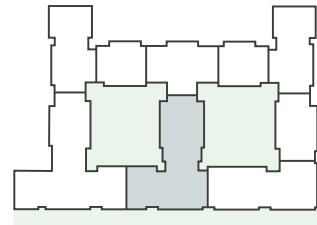

2716 – 2 Bedroom ELITE	70.0 sq m	753 sq ft
Living Space / Kitchen	8.14m x 3.16m	26' 8" x 10' 4"
Master Bedroom	3.00m x 2.76m	9' 10" x 9' 1"
Bedroom 2	4.54m x 2.75m	14' 11" x 9' 0"
Balcony	7.3 sq m	78 sq ft
2717 – 3 Bedroom ELITE	96.4 sq m	1,038 sq ft
Living Space / Kitchen	8.14m x 3.52m	26' 8" x 11' 7"
Master Bedroom	3.33m x 2.75m	10' 11" x 9' 0"
Bedroom 2	3.23m x 2.79m	10' 7" x 9' 2"
Bedroom 3	3.23m x 2.76m	10' 7" x 9' 1"
Balcony	12.4 sq m	133 sq ft
2718 – 3 Bedroom ELITE	96.2 sq m	1,036 sq ft
Living Space / Kitchen	8.14m x 3.52m	26' 8" x 11' 7"
Master Bedroom	3.23m x 2.76m	10' 7" x 9' 1"
Bedroom 2	3.20m x 2.75m	10' 6" x 9' 0"
Bedroom 3	3.20m x 2.78m	10' 6" x 9' 1"
Balcony	12.4 sq m	133 sq ft
2719 – 2 Bedroom ELITE	70.0 sq m	753 sq ft
Living Space / Kitchen	8.16m x 3.16m	26' 9" x 10' 4"
Master Bedroom	3.00m x 2.75m	9' 10" x 9' 0"
Bedroom 2	4.55m x 2.75m	14' 11" x 9' 0"
Balcony	7.3 sq m	78 sq ft
2720 – 1 Bedroom ELITE	51.1 sq m	550 sq ft
Living Space / Kitchen	6.79m x 3.16m	22' 3" x 10' 4"
Bedroom	5.15m x 2.95m	16' 11" x 9' 8"
Balcony	5.9 sq m	64 sq ft
2721 – 1 Bedroom	50.7 sq m	546 sq ft
Living Space / Kitchen	6.33m x 3.41m	20' 9" x 11' 2"
Bedroom	4.13m x 2.97m	13' 7" x 9' 9"
Balcony	8.8 sq m	94 sq ft
2722 – 2 Bedroom	71.4 sq m	769 sq ft
Living Space / Kitchen	7.87m x 3.44m	25' 10" x 11' 3"
Master Bedroom	3.27m x 2.75m	10' 9" x 9' 0"
Bedroom 2	4.17m x 2.75m	13' 8" x 9' 0"
Balcony	8.8 sq m	94 sq ft

APARTMENT KEY

- 1 Bedroom Apartment
- 2 Bedroom Apartment
- 3 Bedroom Apartment

FOXGLOVE HOUSE



-  2 Ring Hob
-  4 Ring Hob
-  Fridge / Freezer
-  Hot Water Cylinder
-  Hot Water Cylinder 300L
-  Washer / Dryer
-  Oven
-  Below Counter Fridge
- C Cupboard



Floorplans shown for Foxglove Apartments are approximate measurements only. Exact layout and sizes may vary. All measurements may vary within a tolerance of 5%. Car park shown for illustrative purposes only. Car parking available subject to additional cost.

Sixth Floor

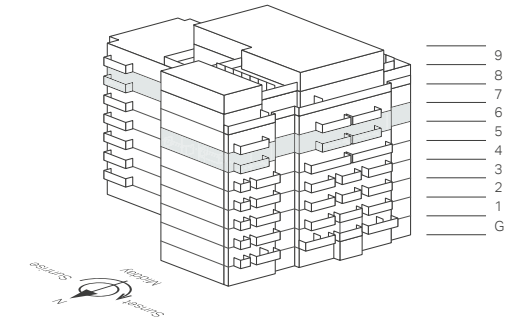

Sixth Floor

2723 – 2 Bedroom ELITE	74.2 sq m	799 sq ft
Living Space / Kitchen	5.72m x 4.12m	18' 8" x 13' 6"
Master Bedroom	3.66m x 2.75m	12' 0" x 9' 0"
Bedroom 2	3.65m x 2.77m	12' 0" x 9' 1"
Balcony	5.2 sq m	56 sq ft
2724 – 2 Bedroom ELITE	70.1 sq m	755 sq ft
Living Space / Kitchen	8.31m x 3.42m	27' 3" x 11' 3"
Master Bedroom	3.00m x 2.75m	9' 10" x 9' 0"
Bedroom 2	3.62m x 2.75m	11' 11" x 9' 0"
Balcony	4.6 sq m	50 sq ft
2725 – 2 Bedroom ELITE	77.3 sq m	832 sq ft
Living Space / Kitchen	8.50m x 3.43m	27' 11" x 11' 3"
Master Bedroom	3.92m x 2.75m	12' 10" x 9' 0"
Bedroom 2	4.82m x 2.75m	15' 10" x 9' 0"
Balcony	5.4 sq m	58 sq ft
2726 – 2 Bedroom ELITE	73.4 sq m	790 sq ft
Living Space / Kitchen	6.96m x 3.73m	22' 10" x 12' 3"
Master Bedroom	3.55m x 3.70m	11' 7" x 12' 2"
Bedroom 2	2.96m x 2.82m	9' 9" x 9' 3"
Balcony	11.2 sq m	120 sq ft
2727 – 2 Bedroom ELITE	73.4 sq m	790 sq ft
Living Space / Kitchen	6.96m x 3.73m	22' 10" x 12' 3"
Master Bedroom	3.55m x 3.70m	11' 7" x 12' 2"
Bedroom 2	2.96m x 2.82m	9' 9" x 9' 3"
Balcony	11.2 sq m	120 sq ft
2728 – 2 Bedroom ELITE	77.3 sq m	832 sq ft
Living Space / Kitchen	8.50m x 3.43m	27' 11" x 11' 3"
Master Bedroom	3.92m x 2.75m	12' 10" x 9' 0"
Bedroom 2	4.82m x 2.75m	15' 10" x 9' 0"
Balcony	5.0 sq m	54 sq ft
2729 – 2 Bedroom ELITE	70.1 sq m	755 sq ft
Living Space / Kitchen	8.31m x 3.42m	27' 3" x 11' 3"
Master Bedroom	3.00m x 2.75m	9' 10" x 9' 0"
Bedroom 2	3.62m x 2.75m	11' 11" x 9' 0"
Balcony	4.9 sq m	53 sq ft
2730 – 2 Bedroom ELITE	73.3 sq m	789 sq ft
Living Space / Kitchen	5.34m x 5.04m	17' 6" x 16' 6"
Master Bedroom	4.39m x 2.85m	14' 5" x 9' 4"
Bedroom 2	3.44m x 2.89m	11' 3" x 9' 6"
Balcony	5.9 sq m	63 sq ft
2731 – 1 Bedroom ELITE	50.0 sq m	538 sq ft
Living Space / Kitchen	5.67m x 3.35m	18' 7" x 11' 0"
Bedroom	3.57m x 2.90m	11' 9" x 9' 6"
Balcony	7.3 sq m	78 sq ft

2732 – 3 Bedroom ELITE	96.6 sq m	1,040 sq ft
Living Space / Kitchen	8.14m x 3.56m	26' 8" x 11' 8"
Master Bedroom	3.24m x 2.76m	10' 8" x 9' 1"
Bedroom 2	3.20m x 2.75m	10' 6" x 9' 0"
Bedroom 3	3.20m. 2.75m	10' 6" x 9' 0"
Balcony	8.8 sq m	94 sq ft
2733 – 3 Bedroom ELITE	96.4 sq m	1,038 sq ft
Living Space / Kitchen	8.14m x 3.52m	26' 8" x 11' 7"
Master Bedroom	3.33m x 2.75m	10' 11" x 9' 0"
Bedroom 2	3.23m x 2.79m	10' 7" x 9' 2"
Bedroom 3	3.23m x 2.76m	10' 7" x 9' 1"
Balcony	8.8 sq m	94 sq ft
2734 – 3 Bedroom ELITE	96.2 sq m	1,036 sq ft
Living Space / Kitchen	8.14m x 3.52m	26' 8" x 11' 7"
Master Bedroom	3.23m x 2.76m	10' 7" x 9' 1"
Bedroom 2	3.20m x 2.75m	10' 6" x 9' 0"
Bedroom 3	3.20m x 2.78m	10' 6" x 9' 1"
Balcony	8.8 sq m	94 sq ft
2735 – 3 Bedroom ELITE	96.3 sq m	1,037 sq ft
Living Space / Kitchen	8.14m x 3.52m	26' 8" x 11' 7"
Master Bedroom	3.23m x 2.76m	10' 7" x 9' 1"
Bedroom 2	3.20m x 2.75m	10' 6" x 9' 0"
Bedroom 3	3.20m x 2.78m	10' 6" x 9' 1"
Balcony	8.8 sq m	94 sq ft
2736 – 1 Bedroom ELITE	50.7 sq m	546 sq ft
Living Space / Kitchen	6.33m x 3.41m	20' 9" x 11' 2"
Bedroom	4.13m x 2.97m	13' 7" x 9' 9"
Balcony	8.8 sq m	94 sq ft
2737 – 2 Bedroom ELITE	71.4 sq m	769 sq ft
Living Space / Kitchen	7.87m x 3.44m	25' 10" x 11' 3"
Master Bedroom	3.27m x 2.75m	10' 9" x 9' 0"
Bedroom 2	4.17m x 2.75m	13' 8" x 9' 0"
Balcony	8.8 sq m	94 sq ft

APARTMENT KEY

- 1 Bedroom Apartment
- 2 Bedroom Apartment
- 3 Bedroom Apartment

FOXGLOVE HOUSE

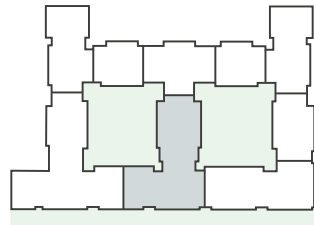

- 2 Ring Hob
- 4 Ring Hob
- Fridge / Freezer
- Hot Water Cylinder
- Hot Water Cylinder 300L
- Washer / Dryer
- Oven
- Below Counter Fridge
- C Cupboard

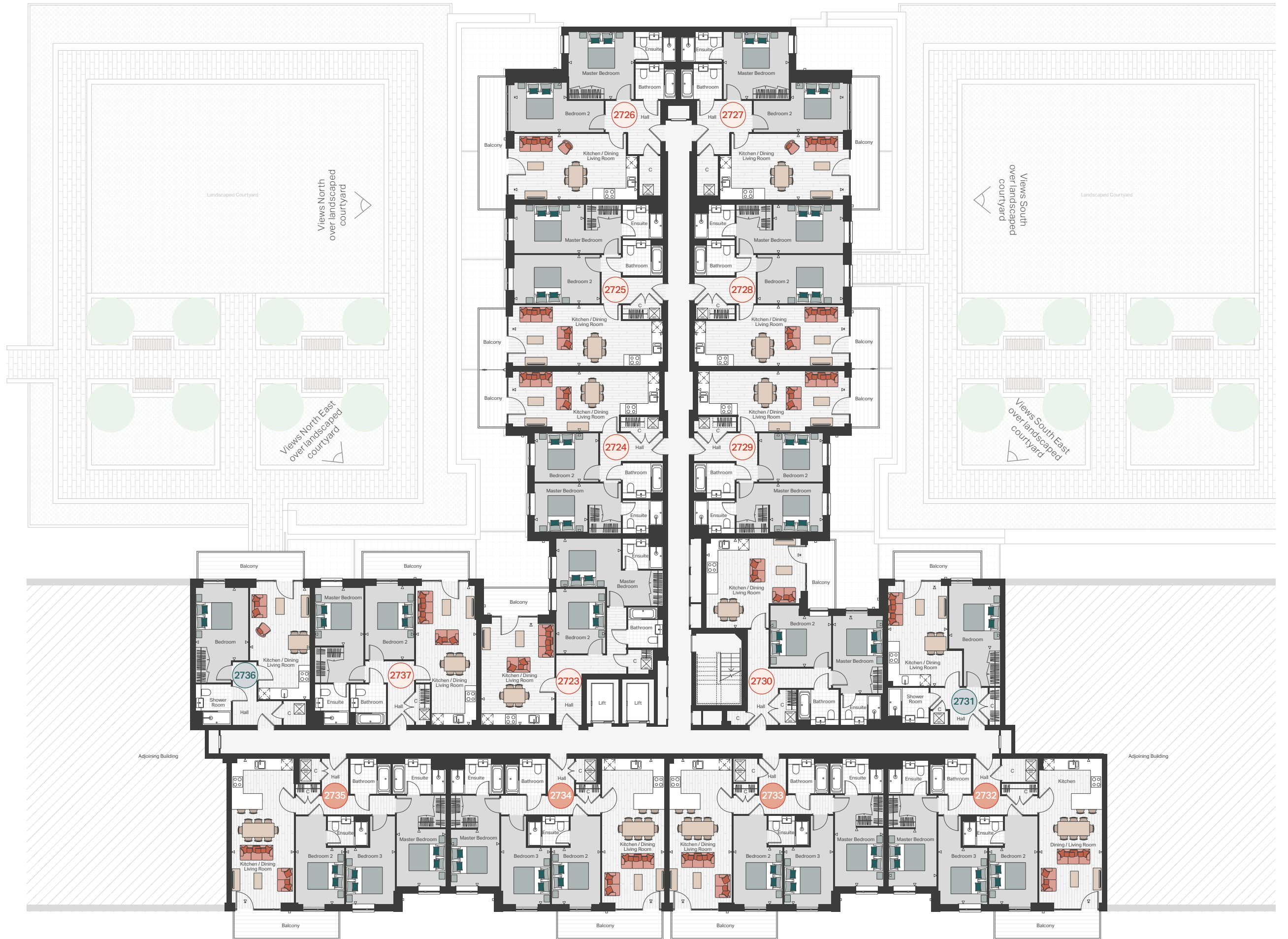

Floorplans shown for Foxglove Apartments are approximate measurements only. Exact layout and sizes may vary. All measurements may vary within a tolerance of 5%. Car park shown for illustrative purposes only. Car parking available subject to additional cost.

Seventh Floor

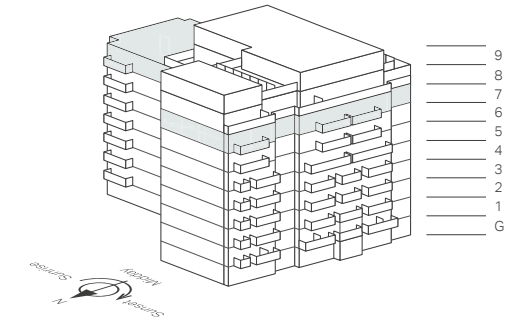

Seventh Floor

2738 – 2 Bedroom ELITE 74.2 sq m 799 sq ft

Living Space / Kitchen	5.72m x 4.12m	18' 8" x 13' 6"
Master Bedroom	3.66m x 2.75m	12' 0" x 9' 0"
Bedroom 2	3.65m x 2.77m	12' 0" x 9' 1"
Balcony	5.2 sq m	56 sq ft

2739 – 2 Bedroom ELITE 70.1 sq m 755 sq ft

Living Space / Kitchen	8.31m x 3.42m	27' 3" x 11' 3"
Master Bedroom	3.00m x 2.75m	9' 10" x 9' 0"
Bedroom 2	3.62m x 2.75m	11' 11" x 9' 0"
Balcony	4.6 sq m	50 sq ft

2740 – 2 Bedroom ELITE 77.3 sq m 832 sq ft

Living Space / Kitchen	8.50m x 3.43m	27' 11" x 11' 3"
Master Bedroom	3.92m x 2.75m	12' 10" x 9' 0"
Bedroom 2	4.82m x 2.75m	15' 10" x 9' 0"
Balcony	5.4 sq m	58 sq ft

2741 – 2 Bedroom ELITE 73.4 sq m 790 sq ft

Living Space / Kitchen	6.96m x 3.73m	22' 10" x 12' 3"
Master Bedroom	3.55m x 3.70m	11' 7" x 12' 2"
Bedroom 2	2.96m x 2.82m	9' 9" x 9' 3"
Balcony	11.2 sq m	120 sq ft

2742 – 2 Bedroom ELITE 73.4 sq m 790 sq ft

Living Space / Kitchen	6.96m x 3.73m	22' 10" x 12' 3"
Master Bedroom	3.55m x 3.70m	11' 7" x 12' 2"
Bedroom 2	2.96m x 2.82m	9' 9" x 9' 3"
Balcony	11.2 sq m	120 sq ft

2743 – 2 Bedroom ELITE 77.3 sq m 832 sq ft

Living Space / Kitchen	8.50m x 3.43m	27' 11" x 11' 3"
Master Bedroom	3.92m x 2.75m	12' 10" x 9' 0"
Bedroom 2	4.82m x 2.75m	15' 10" x 9' 0"
Balcony	5.0 sq m	54 sq ft

2744 – 2 Bedroom ELITE 70.1 sq m 755 sq ft

Living Space / Kitchen	8.31m x 3.42m	27' 3" x 11' 3"
Master Bedroom	3.00m x 2.75m	9' 10" x 9' 0"
Bedroom 2	3.62m x 2.75m	11' 11" x 9' 0"
Balcony	4.9 sq m	53 sq ft

2745 – 2 Bedroom ELITE 73.2 sq m 788 sq ft

Living Space / Kitchen	5.34m x 5.04m	17' 6" x 16' 6"
Master Bedroom	4.39m x 2.85m	14' 5" x 9' 4"
Bedroom 2	3.44m x 2.89m	11' 3" x 9' 6"
Balcony	5.9 sq m	63 sq ft

2746 – 1 Bedroom ELITE 50.0 sq m 538 sq ft

Living Space / Kitchen	5.67m x 3.35m	18' 7" x 11' 0"
Bedroom	3.57m x 2.90m	11' 9" x 9' 6"
Balcony	7.3 sq m	78 sq ft

2747 – 3 Bedroom PREMIER 96.6 sq m 1,040 sq ft

Living Space / Kitchen	8.14m x 3.56m	26' 8" x 11' 8"
Master Bedroom	3.24m x 2.76m	10' 8" x 9' 1"
Bedroom 2	3.20m x 2.75m	10' 6" x 9' 0"
Bedroom 3	3.20m x 2.75m	10' 6" x 9' 0"
Balcony	8.8 sq m	94 sq ft

2748 – 3 Bedroom PREMIER 96.4 sq m 1,038 sq ft

Living Space / Kitchen	8.14m x 3.52m	26' 8" x 11' 7"
Master Bedroom	3.33m x 2.75m	10' 11" x 9' 0"
Bedroom 2	3.23m x 2.79m	10' 7" x 9' 2"
Bedroom 3	3.23m x 2.76m	10' 7" x 9' 1"
Balcony	8.8 sq m	94 sq ft

2749 – 3 Bedroom PREMIER 96.2 sq m 1,036 sq ft

Living Space / Kitchen	8.14m x 3.52m	26' 8" x 11' 7"
Master Bedroom	3.23m x 2.76m	10' 7" x 9' 1"
Bedroom 2	3.20m x 2.75m	10' 6" x 9' 0"
Bedroom 3	3.20m x 2.78m	10' 6" x 9' 1"
Balcony	8.8 sq m	94 sq ft

2750 – 3 Bedroom PREMIER 96.3 sq m 1,037 sq ft

Living Space / Kitchen	8.14m x 3.52m	26' 8" x 11' 7"
Master Bedroom	3.23m x 2.76m	10' 7" x 9' 1"
Bedroom 2	3.20m x 2.75m	10' 6" x 9' 0"
Bedroom 3	3.20m x 2.78m	10' 6" x 9' 1"
Balcony	8.8 sq m	94 sq ft

2751 – 1 Bedroom ELITE 50.7 sq m 546 sq ft

Living Space / Kitchen	6.33m x 3.41m	20' 9" x 11' 2"
Bedroom	4.13m x 2.97m	13' 7" x 9' 9"
Balcony	8.8 sq m	94 sq ft

2752 – 2 Bedroom ELITE 71.4 sq m 769 sq ft

Living Space / Kitchen	7.87m x 3.44m	25' 10" x 11' 3"
Master Bedroom	3.27m x 2.75m	10' 9" x 9' 0"
Bedroom 2	4.17m x 2.75m	13' 8" x 9' 0"
Balcony	8.8 sq m	94 sq ft

APARTMENT KEY

- 1 Bedroom Apartment
- 2 Bedroom Apartment
- 3 Bedroom Apartment

FOXGLOVE HOUSE

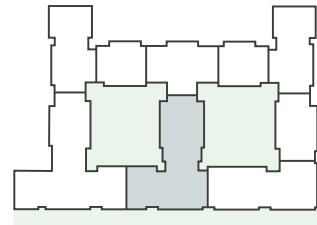

- 2 Ring Hob
- 4 Ring Hob
- Fridge / Freezer
- Hot Water Cylinder
- Hot Water Cylinder 300L
- Washer / Dryer
- Oven
- Below Counter Fridge
- C Cupboard

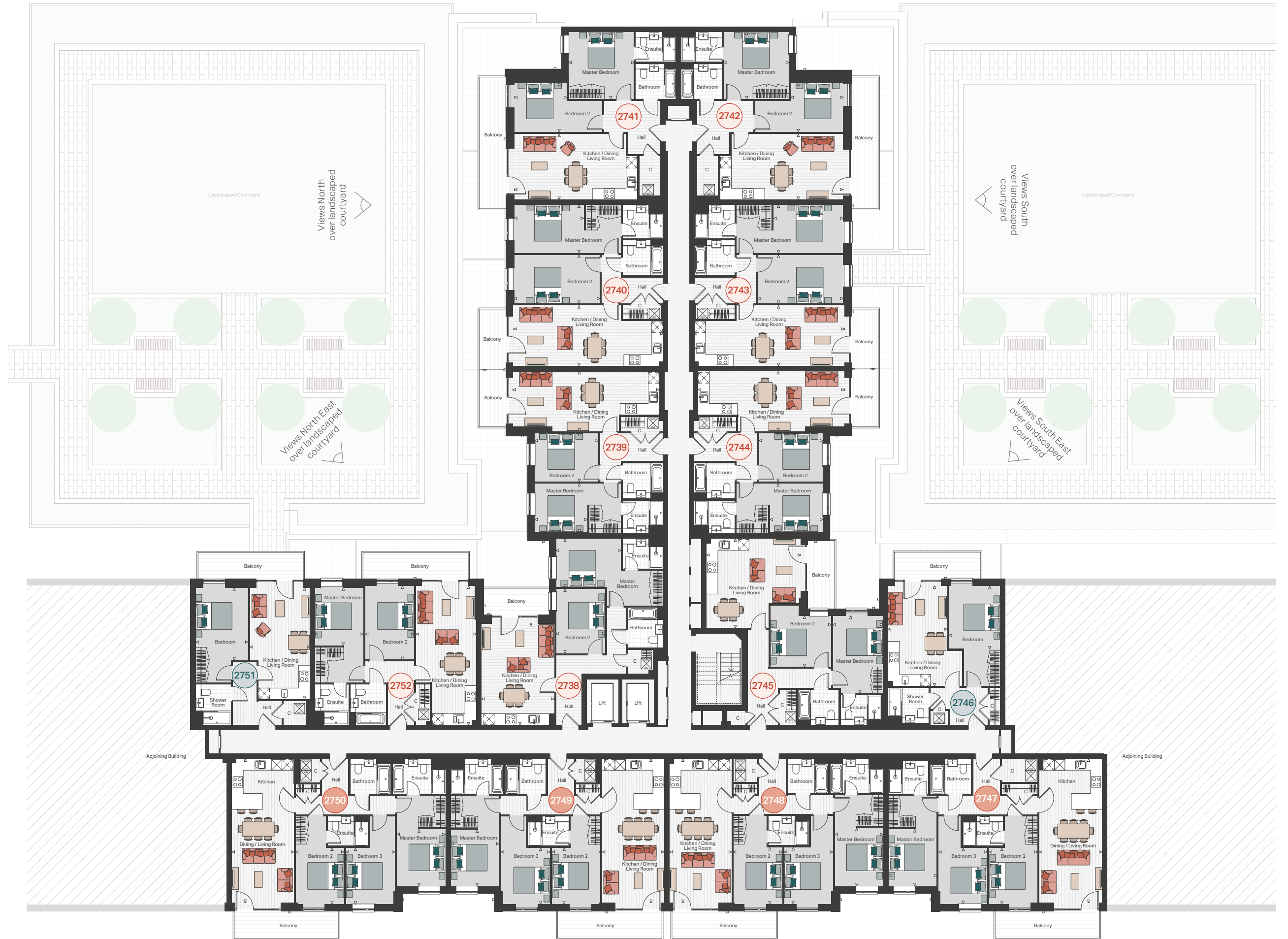

Floorplans shown for Foxglove Apartments are approximate measurements only. Exact layout and sizes may vary. All measurements may vary within a tolerance of 5%. Car park shown for illustrative purposes only. Car parking available subject to additional cost.

Views West over Landscaped Park

Views West over Landscaped Park

Views West over Landscaped Park

Eighth Floor

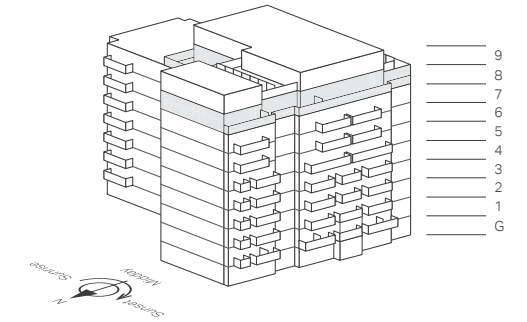

Eighth Floor

2753 – 2 Bedroom ELITE	76.2 sq m	820 sq ft
Living Space / Kitchen	5.84m x 5.67m	19' 2" x 18' 7"
Master Bedroom	4.14m x 2.75m	13' 7" x 9' 0"
Bedroom 2	3.87m x 2.77m	12' 8" x 9' 1"
Balcony	5.4 sq m	58 sq ft

2754 – 2 Bedroom ELITE	75.6 sq m	814 sq ft
Living Space / Kitchen	6.80m x 4.29m	22' 4" x 14' 1"
Master Bedroom	3.51m x 3.41m	11' 6" x 11' 2"
Bedroom 2	3.41m x 3.15m	11' 2" x 10' 4"
Terrace	72.0 sq m	775 sq ft

2755 – 2 Bedroom ELITE	75.6 sq m	814 sq ft
Living Space / Kitchen	6.77m x 4.29m	22' 3" x 14' 1"
Master Bedroom	3.50m x 3.38m	11' 6" x 11' 1"
Bedroom 2	3.38m x 3.15m	11' 1" x 10' 4"
Terrace	72.0 sq m	775 sq ft

2756 – 2 Bedroom ELITE	74.3 sq m	800 sq ft
Living Space / Kitchen	5.27m x 5.25m	17' 3" x 17' 3"
Master Bedroom	4.39m x 2.85m	14' 5" x 9' 4"
Bedroom 2	3.44m x 2.89m	11' 3" x 9' 6"
Balcony	5.6 sq m	60 sq ft

2757 – 3 Bedroom PREMIER	104.0 sq m	1,119 sq ft
Living Space / Kitchen	6.40m x 5.00m	21' 0" x 16' 5"
Master Bedroom	4.78m x 2.75m	15' 8" x 9' 0"
Bedroom 2	3.43m x 2.80m	11' 3" x 9' 2"
Bedroom 3	4.21m x 2.75m	13' 10" x 9' 0"
Terrace	22.2 sq m	239 sq ft

2758 – 2 Bedroom ELITE	79.2 sq m	853 sq ft
Living Space / Kitchen	7.12m x 6.23m	23' 4" x 20' 5"
Master Bedroom	3.40m x 3.07m	11' 2" x 10' 1"
Bedroom 2	3.57m x 2.89m	11' 9" x 9' 6"
Terrace	21.0 sq m	226 sq ft

2759 – 4 Bedroom Penthouse PREMIER	163.9 sq m	1,764 sq ft
Living Space / Kitchen	8.40m x 7.31m	27' 7" x 24' 0"
Master Bedroom	4.22m x 2.90m	13' 10" x 9' 6"
Bedroom 2	3.66m x 3.12m	12' 0" x 10' 3"
Bedroom 3	3.56m x 3.04m	11' 8" x 10' 0"
Bedroom 4	3.09m x 2.65m	10' 2" x 8' 8"
Terrace	71.7 sq m	772 sq ft

2760 – 2 Bedroom ELITE	74.6 sq m	803 sq ft
Living Space / Kitchen	5.84m x 4.90m	19' 2" x 16' 1"
Master Bedroom	3.55m x 2.75m	11' 8" x 9' 0"
Bedroom 2	3.55m x 2.97m	11' 8" x 9' 9"
Terrace	20.4 sq m	220 sq ft

APARTMENT KEY

- 2 Bedroom Apartment
- 3 Bedroom Apartment
- 4 Bedroom Penthouse

FOXLGLOVE HOUSE

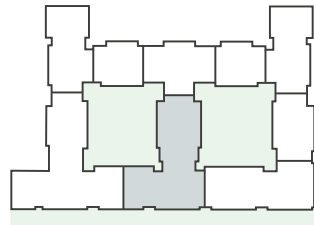

- 2 Ring Hob
- 4 Ring Hob
- Fridge / Freezer
- Hot Water Cylinder
- Hot Water Cylinder 300L
- Washer / Dryer
- Oven
- Below Counter Fridge
- C Cupboard



Floorplans shown for Foxglove Apartments are approximate measurements only. Exact layout and sizes may vary. All measurements may vary within a tolerance of 5%. Car park shown for illustrative purposes only. Car parking available subject to additional cost.

Ninth Floor

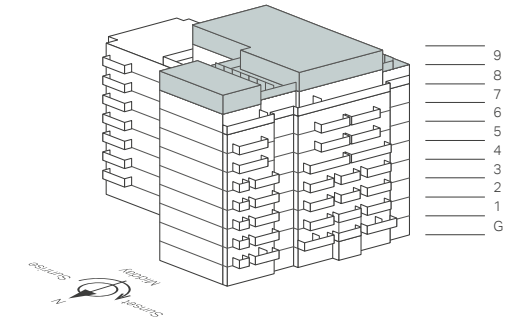

Ninth Floor Penthouses

● 2759 – 4 Bedroom Penthouse 163.9 sq m 1,764 sq ft
PREMIER

Living Space / Kitchen	8.40m x 7.31m	27' 7" x 24' 0"
Master Bedroom	4.22m x 2.90m	13' 10" x 9' 6"
Bedroom 2	3.66m x 3.12m	12' 0" x 10' 3"
Bedroom 3	3.56m x 3.04m	11' 8" x 10' 0"
Bedroom 4	3.09m x 2.65m	10' 2" x 8' 8"
Terrace	71.7 sq m	772 sq ft

● 2761 – 3 Bedroom Penthouse 125.0 sq m 1,346 sq ft
ELITE

Living Space / Kitchen	6.70m x 6.56m	22' 0" x 21' 6"
Master Bedroom	3.90m x 3.21m	12' 10" x 10' 6"
Bedroom 2	3.77m x 2.90m	12' 4" x 9' 6"
Bedroom 3	3.87m x 3.04m	12' 8" x 10' 0"
Balcony	8.8 sq m	94 sq ft

● 2762 – 3 Bedroom Penthouse 117.2 sq m 1,262 sq ft
ELITE

Living Space / Kitchen	6.74m x 5.93m	22' 1" x 19' 5"
Master Bedroom	4.39m x 3.03m	14' 5" x 9' 11"
Bedroom 2	3.79m x 2.85m	12' 5" x 9' 4"
Bedroom 3	3.90m x 2.75m	12' 10" x 9' 0"
Balcony	8.8 sq m	94 sq ft

● 2763 – 3 Bedroom Penthouse 126.4 sq m 1,361 sq ft
PREMIER

Living Space / Kitchen	10.10m x 5.53m	33' 2" x 18' 2"
Master Bedroom	4.35m x 2.63m	14' 3" x 8' 8"
Bedroom 2	4.06m x 4.08m	13' 4" x 13' 5"
Bedroom 3	4.06m x 2.85m	13' 4" x 9' 4"
Terrace	117.6 sq m	1,266 sq ft

APARTMENT KEY

- 3 Bedroom Apartment
- 4 Bedroom Penthouse

FOXLGLOVE HOUSE

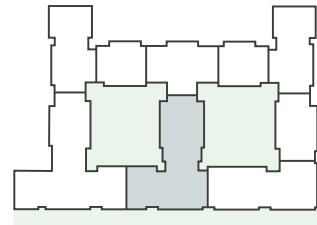

- 2 Ring Hob
- 4 Ring Hob
- Fridge / Freezer
- Hot Water Cylinder
- Hot Water Cylinder 300L
- Washer / Dryer
- Oven
- Below Counter Fridge
- Cupboard



Floorplans shown for Foxglove Apartments are approximate measurements only. Exact layout and sizes may vary. All measurements may vary within a tolerance of 5%. Car park shown for illustrative purposes only. Car parking available subject to additional cost.



Bedroom



Light-filled spaces

GENERAL

- Feature architrave and skirting
- Double-glazed windows
- Balcony or terrace to all apartments
- Wardrobe inclusive of shelf and rail, to Master bedroom¹
- Matt emulsion paint finish to walls and ceilings
- Managed residents' gated car parking²
- 999-year lease from December 2005
- 2-year St George warranty
- 10-year insurance backed building warranty

¹ Except studio apartments.
² Available at an additional cost, subject to availability.



Living and dining

APARTMENT SPECIFICATION

Stylish and modern, each apartment features a balcony or terrace, alongside contemporary fittings.



SECURITY

- Colour video entryphone system
- Mains-operated smoke detectors to hallways and communal areas
- 24-hour estate management³
- Monitored CCTV security system³

COMMUNAL AREAS

- Landscaped public areas³
- Access to The Spa, residents' health and fitness suite³
- Lifts to all floors
- Low-level feature lighting to landscaped areas³
- Stylishly designed entrance lobby with feature wall and timber panelling

³ Payable via the service charge.



Opposite page Kitchen and dining area



Kitchen

KITCHEN

- Custom-designed fitted kitchen with slimline laminate kitchen worktop
- Feature tile splashback
- Integrated fridge / freezer
- Integrated dishwasher (except studio apartments)
- Integrated oven and touch control induction hob
- Grade A energy-efficient kitchen appliances¹
- Integrated extractor
- Stainless steel bowl sink and black mixer tap to Studio, Manhattan and 1 bedroom apartments
- Stainless steel 1½ bowl sink with black mixer tap to two, three and four bedroom apartments
- Under-wall unit LED lighting
- Washer / dryer in hall cupboard

The specification comes as standard with every apartment. Your attention is drawn to the fact that it may not be possible to obtain the branded products as referred to in the specification. In such cases, a similar alternative will be provided. St George reserves the right to make these changes as required.



Kitchen storage

BATHROOM / EN SUITE & SHOWER ROOM

- Stylishly designed bathrooms and en suites with tiled floors and tiled wall
- Basin and WC
- Black-finished taps
- Glass screen above bath where no separate shower enclosure within the same bathroom
- Screen to all separate showers
- Heated black towel rail
- Toilet roll holder
- Low-level vanity cabinet



Bathroom



Integrated SMEG oven

FLOORING

- Wood-effect flooring to living space, hallway and kitchen
- Carpet to bedrooms (wood-effect flooring in Manhattan and studio apartments)

ELECTRICAL

- LED downlighters to living space, kitchen, bathrooms and hallway with dimmer switch to living space
- Satellite TV and FM terrestrial TV points to living space and all bedrooms
- Electric panel heaters
- Telephone point
- Digital media box and one year pre-paid¹
- Sky Q contract installed and operational¹
- USB charging points to living space, kitchen and bedroom¹
- Pendant light to bedrooms
- Black sockets to kitchen, white sockets and switches to all other areas

¹ Terms and conditions apply, please liaise with the Sales Consultants for further details.



Living and dining

ELITE UPGRADE SPECIFICATION



Kitchen

Composite stone kitchen worktop



Built-in wardrobes

ENHANCE THE SPECIFICATION OF YOUR APARTMENT WITH AN ELITE UPGRADE

- Integrated wine cooler (size dependent on apartment type)
- Integrated microwave
- Composite stone kitchen worktop
- Composite stone top to bathroom vanity cabinet
- Black light switches and sockets throughout¹
- LED downlighters throughout
- Enhanced wardrobe with drawers, shelf and rail to Master Bedroom
- Feature mirrored bathroom wall cabinet



Bathroom

¹ Where concealed behind appliances or within cupboards, sockets and switches are white. Upgrade specification available as a complete package at extra cost when you purchase a standard apartment. Please see the Sales Consultants for further information. Interior photographs is of Beaufort Park and is indicative only. Your attention is drawn to the fact that it may not be possible to obtain the branded products as referred to in the specification. In such cases, a similar alternative will be provided. St George reserves the right to make these changes as required.

PREMIER SPECIFICATION

The Premier Specification is the finest in modern apartment living, fitting out your home with the finest details throughout.

The premier apartments offer the finest in modern apartment living.

The quality specification has been created to suitably reflect its prime location. From the custom-designed fitted kitchens to the elegant porcelain

tiled bathrooms and en suites, each detail speaks of quality and style. Features such as dimmable lighting and an LED television in the living area further enhance the feeling of sophistication.



GENERAL

- Comfort cooling to living space and bedrooms¹
- Balcony or terrace to all apartments
- Built-in wardrobe to bedrooms 1 & 2, with internal lighting and drawers²
- 999-year lease from December 2005
- 2-year St George warranty
- 10-year insurance-backed building warranty
- Double-glazed windows
- Managed residents' gated car parking³

¹ The comfort cooling system is designed to provide an ambient temperature within the apartment for the majority of external temperatures. This may not be achieved in extreme temperature conditions.

² 3 bedroom apartments only.

³ Available at an additional cost, subject to availability.



Integrated appliances



Stone worktop and splashback

KITCHEN

- Custom-designed fitted kitchen
- Composite stone kitchen worktops and splashback
- Integrated stainless steel oven, microwave and touch control induction hob
- Integrated stainless steel extractor
- Integrated wine cooler
- Integrated fridge / freezer
- Integrated dishwasher
- Stainless steel 1½ sink bowl with chrome mixer tap and waste disposal unit
- Full-height storage cabinet²
- Corner carousel cabinet²
- Cutlery drawer inserts
- Washer / dryer in hallway cupboard

² Subject to kitchen design.



Shower room

ELECTRICAL

- LED downlighters throughout with dimmer switches to living space and bedrooms 1, 2 & 3
- 50" 4K LED smart TV to living space
- Digital media box and one-year pre-paid contract installed and operational⁴
- USB charging points to living space, kitchen and bedroom⁴
- External light fittings to terraces only
- Telephone points to living space
- Black sockets and switches throughout⁵

⁴ Terms and conditions apply, please liaise with the Sales Consultants for further details.

⁵ Where concealed behind appliances or within cupboards, sockets and switches are white. In such cases, a similar alternative will be provided. St George reserves the right to make these changes as required.



Master Bedroom

BATHROOM / EN SUITE & SHOWER ROOM

- Stylishly designed bathrooms and en suites, with feature wall tiles and tiled floors
- Feature heated wall with black robe hooks and towel rail
- White oversized bath with black-finished taps to main bathroom only
- Black-finished showering set to shower enclosure
- Feature demisting mirrored wall cabinet with open shelving and perimeter lighting
- Low-level vanity unit with composite stone countertop and black tap
- Toilet roll holder

FLOORING

- Engineered timber flooring to living space, kitchen and hallway
- Carpet to bedrooms
- Underfloor heated tiling to bathroom and en suite(s)

Computer generated image and interior photography are of Beaufort Park and are indicative only. Your attention is drawn to the fact that it may not be possible to obtain the branded products as referred to in the specification. In such cases, a similar alternative will be provided. St George reserves the right to make these changes as required.



Living space



DESIGNED FOR LIFE

Our customers are at the heart of all our decisions. We aim to understand their needs and consistently meet or exceed their expectations. The service we provide is professional, efficient and helpful to make the home-buying process as straightforward and enjoyable as possible. Our levels of customer service aim to be comparable to other top brands.

Customer service is our priority

All our customers are provided with a commitment that when they buy a new home from St George they can be safe in the knowledge that it is built to very high standards of design and quality, has low environmental impact and that they will enjoy an exceptional customer experience. Each customer receives tailored information relating to their purchase and has a dedicated point of contact throughout the customer journey.

Green living and sustainable development is top of our agenda

As a company, we are committed to reducing energy, water and waste on our construction sites, in our offices and in the homes that we build. Almost all of our developments are built on brownfield land and we always take care to protect and enhance biodiversity and natural habitats. Our homes include features to encourage sustainable living such as dual-flush WCs, recycling bins and energy-efficient white goods.

Quality is at the heart of everything we do

At St George, quality takes precedence, from choosing the right location and style of home, to the construction processes we practice, the materials we use and the specifications we put into our homes. For extra peace of mind, in addition to the 10-year warranty all new homes receive, St George operates a 2-year policy with dedicated Customer Service teams on hand 24 hours a day to deal with enquiries quickly and effectively.

Unparalleled choice of homes in the most sought after locations

As one of the UK's leading housebuilders, we are able to offer our customers an unrivalled choice of property location, size and type. From city penthouses to country retreats, modern studio apartments to traditional family homes, you will find the perfect home to match your requirements. Our homes are also built in some of Britain's most desirable locations from market towns and rural villages to major towns and cities, and countryside to the coast – we build in the locations you want to live.

A commitment to creating sustainable communities

St George homes and developments are not just built for today. They are designed to enhance the neighbourhoods in which they are located permanently. We achieve this through our commitment to excellence in design, sensitive landscaping, sympathetic restoration, and impeccable standards of sustainability. We aim to address the needs not only of our customers but their neighbours and the broader community of which they are a part. It is a long-term view: we want to create exceptional places for people to live, work and relax in, and build communities that will thrive today and for years to come.



A COMMITMENT TO THE FUTURE

Over the years, The Berkeley Group has won many prestigious awards for the quality, design and sustainability of its developments.

Our Vision is Berkeley's plan for the business, designed to raise standards higher still. Our goal is to be a world-class company creating successful, sustainable places where people aspire to live.

We take our responsibilities towards our customers, the environment, the workforce and the communities in which we work very seriously.

Our plan for the business has five areas of focus: Customers, Homes, Places, Operations and Our People.

OUR VISION

To be a world-class business generating long-term value by creating successful, sustainable places where people aspire to live.

FIVE FOCUS AREAS

<p>An exceptional customer experience</p> <p>We aim to put customers at the heart of our decisions. Dedicated sales teams will provide exceptional service throughout the buying process, and teams will manage the customer relationship from exchange of contracts through to completion, delivery of the new home and after occupancy.</p>	<p>High-quality homes</p> <p>When you buy a new home from Berkeley you can be safe in the knowledge that it is built to very high standards of design and quality and has low environmental impact. We meet specific space standards for new homes and aim to deliver a home which has fibre broadband infrastructure.</p>	<p>Great places</p> <p>We seek to create beautiful, successful places characterised by the quality of their design, external spaces, transport and access to jobs and amenities. These are places where people choose to live, work and spend their time and which directly encourage people's well-being and quality of life.</p>	<p>Efficient and considerate operations</p> <p>We reduce the impact of the construction process on the local community by registering all of our sites with the Considerate Constructors Scheme. We set targets to reduce water, energy and waste. We work with our supply chain to ensure high-quality services and materials are consistently provided.</p>
<p>A commitment to people and safety</p> <p>Safety is a high priority on all of our construction sites. We also aim to have a positive impact on society and enable young and unemployed people to get into work through our support of the Berkeley Foundation.</p>			



Berkeley takes social responsibility very seriously. In 2011 we set up The Berkeley Foundation, with the aim of supporting Britain's young people and their communities.

We do this through a number of partner charities that tackle some of the most pressing social problems affecting young people today, including homelessness and unemployment. The money raised comes partly from the Berkeley Group, and also through the tireless and inventive efforts of our staff.

We have set a goal for The Berkeley Foundation to invest £10 million over the next five years to support young people and their communities. Every penny will be spent on charitable activities and worthy causes to ensure that maximum benefit is achieved.



WHAT IS MYHOME PLUS?

MyHome Plus is a new online service that is designed to help you manage key aspects of your new home at any time from anywhere around the world.



BUYING PROCESS

This section provides you with a step-by-step guide to the buying process from reservation through to completion, moving in and warranty. At each milestone, the buying process section advises on the next steps so that you can be absolutely clear on your current position and what to expect next.

1. FILING CABINET

In the filing cabinet section you can access documentation relating to your new home immediately at your own convenience.

2. MEET THE TEAM

This section provides an introduction to the team that will be working with you throughout your journey and details their individual roles. You can email any member of the team directly via this section.

3. OPTIONS & CHOICES SELECTION

We are able to offer some choices on certain internal finishes of your new home. Whether this option is available to you will depend on what stage of construction the property has reached at the time of you making your reservation. See the next steps section for further detail on this.

4. CONSTRUCTION PROGRESS

Under this section, regular updates on the construction of your new property will be provided, keeping you up to date on the progress on site and the local area. Your Customer Service Manager will issue regular newsletters and photographs to this section throughout your journey.

NEXT STEPS

- 1 Your Sales Consultant will send you a link that you will need to activate to access MyHome Plus. The link will require you to set a password for access.
- 2 Customer Service will then be in touch to invite you into our Show Apartment to view the interior selections available for the internal finishes that you have an option to select. If you cannot make it to the appointment, the options can be discussed over the telephone and selected via MyHome Plus. Customer Service will need to receive your choices selection by the deadline date, which will be given in advance.

AT YOUR SERVICE

From your first visit to the Beaufort Park Show Apartments and Marketing Suite through to completion of your new home and subsequent warranty period, St George is here to provide an exceptional personal service.

It's our team's special touches that make those months of anticipation a truly exciting time. We will provide you with regular progress updates throughout the construction of the apartment. We will also help you find your style among the bespoke interior design options for your kitchen, bathroom and flooring, via our dedicated selection process.

You can take a guided tour of Beaufort Park and your new home during the construction phase.

When your moving date arrives, we will be there to present your keys and provide a full demonstration of your apartment. Our dedicated service and warranty extends for a further two years after you move in.

SHOW APARTMENTS & MARKETING SUITE

16-18 Aerodrome Road,
London NW9 5GW

OPENING HOURS

Mon–Sat 10am–6pm
Sun 10am–5pm
Bank Holidays 10am–4pm

CONTACT DETAILS

+44 (0)20 8511 8600
sales@beaufortpark.co.uk
beaufortpark.co.uk



The information in this document is indicative and is intended to act as a guide only as to the finished product. Accordingly, due to St George's policy of continuous improvement, the finished product may vary from the information provided. These particulars should not be relied upon as statements of fact or representations and applicants must satisfy themselves by inspection or otherwise as to their correctness. This information does not constitute a contract or warranty. Foxglove House is a marketing name and will not necessarily form part of the approved postal address. Applicants are advised to contact St George to ascertain the availability of any particular property. 34CAIH04410120. Purchasing uncompleted properties located outside Hong Kong is complicated and contains risk. You should review all relevant information and documents carefully. If in doubt, please seek independent professional advice before making a purchase decision. Planning permission number: H/04672/14, 18/3505/NMA, W00198AA/04. Borough/council issuing permission: London Borough of Barnet. Acquiring interest: 999-year leasehold interest from December 2005.



Sign in by visiting berkeleygroup.co.uk/my-home/sign-in





beaufortpark.co.uk